

MASTERING VENTILATION

WINDOW VENTS





CONTENTS

Overview	4
Why ventilate?	6
Regulations	8
I-Flux® technology	11
Support from A to Z	12
Why Renson?	14
Product overview	17
Overframe window vents	19
Flap ventilators glazed-in/at transom	33
Roller shutter flap ventilator	51
Sliding vents	55
Slotvents	61
Combined ventilation and Sun Protection overframe	73
General	82
Ambassadorship	89

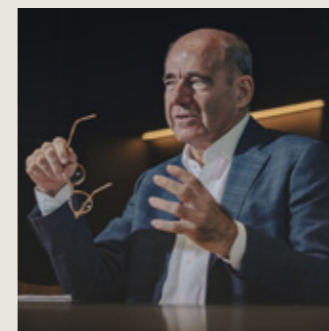

// Our passion lies in creating innovative products and complete solutions that turn every home into a healthy and comfortable place to live. Our commitment to 'creating healthy spaces' is the foundation of everything we do.
Paul Renson //

PRODUCT OVERVIEW

	Page	Equivalent Area (mm ² /m)	Q at 1 Pa (l/s/m)	Q at 1 Pa (m ³ /h/m)	Q at 2 Pa (l/s/m)	Q at 2 Pa (m ³ /h/m)	Q at 10 Pa (l/s/m)	Q at 20 Pa (l/s/m)	Free area (mm ² /m)	Sound reduction D _{n,w} (C;C _w) in open position (dB/m)	i-Flux [®]	Control	U value (W/m ² K)	Watertightness in closed position (Pa)	Watertightness in open position (Pa)	Glass reduction (mm)	Glass thickness (mm)	Finishing	Maximum length (mm)
Overframe windowvents																			
Invisivent [®] AIR Light	21	13479	10.6	38.1	17.2	62.0	16.4	19.2	14388.5	31 (-1;-2)	Yes	5 positions	2.0	900	150 - 250 ****	0	n/a	natural colour / RAL / dual colour	6000
Invisivent [®] AIR Basic	22	13429	10.6	38.0	17.2	62.0	17.6	17.3	13975.5	34 (0;-1)	Yes	5-16 positions*****	1.8	900 - 1200 *****	150 - 250 ****	0	n/a	natural colour / RAL / dual colour	6000
Invisivent [®] AIR High	23	11364	8.9	32.2	12.1	43.4	11.9	14.3	10273	40 (0;-2)	Yes	5-16 positions*****	1.8	900 - 1200 *****	150 - 250 ****	0	n/a	natural colour / RAL / dual colour	6000
Invisivent [®] COMFORT Basic	25	4311	3.4	12.2	6.0	21.6	18.8	24.0	3900	35 (-1;-2)	Yes	5-16 positions*****	1.8	900 - 1200 *****	150 - 250 ****	0	n/a	natural colour / RAL / dual colour	6000
Invisivent [®] COMFORT High	26	2936	2.3	8.3	4.7	16.8	12.4	18.2	3606	39 (0;-2)	Yes	5-16 positions*****	1.8	900 - 1200 *****	150 - 250 ****	0	n/a	natural colour / RAL / dual colour	6000
Invisivent [®] COMFORT Ultra	27	2356	1.9	6.7	3.3	11.8	10.0	14.4	3606	42 (0;-2)	Yes	5-16 positions*****	1.7	900 - 1200 *****	150 - 250 ****	0	n/a	natural colour / RAL / dual colour	6000
Invisivent [®] COMFORT Extreme	28	213	0,2	0,6	0,8	2,9	4,4	6,2	3606	48 (0;-2)	Yes	5-16 positions*****	1.7	900 - 1200 *****	250	0	n/a	natural colour / RAL / dual colour	6000
Flap ventilators glazed-in/at transom																			
TC60	34	15652	12,3	44,3	17,4	62,6	38,9	55,0	12314	28 (0;0)	No	Infinitely adjustable	3.3	650	-	60	20/24/28	natural colour / RAL / dual colour	2000
AR60	36	10427	8,2	29,5	11,8	42,3	19,7	23,9	14900	27 (0;0)	Yes	5 positions	4.5	650	100	60	20/24/28	natural colour / RAL / dual colour	3500
AR90	38	14252	11,2	40,3	15,6	56,2	11,4	9,1	11070	30 (-1;-2)	No	5 positions	3.9	650	100	90	20/24/28	natural colour / RAL / dual colour	2500 (2000 mm with motor control)
THM90 [®]	40	11841	9,3	33,5	13,9	50,0	13,5	15,1	11200	26 (0;0)	No	5 positions	3.8	650	100	90	20/24/28/33*	natural colour / RAL / dual colour	2500 (2000 mm with motor control)
Variavent Small NEW	42	12725	10	36	14,2	-	12,7	13,6	-	25 (-1;-1)	Yes	Infinitely adjustable	2.8	650	50	80	20/24/28/32/36/40/44*	natural colour / RAL / dual colour	3000
Variavent Medium NEW	42	19088	15	54	21,4	-	19,1	20,4	-	25 (-1;-1)	Yes	Infinitely adjustable	2.8	650	50	80	20/24/28/32/36/40/44*	natural colour / RAL / dual colour	3000
Variavent Large NEW	42	22905	18	64,8	19,1	-	22,9	24,4	-	25 (-1;-1)	Yes	Infinitely adjustable	2.8	650	50	80	20/24/28/32/36/40/44*	natural colour / RAL / dual colour	3000
Variavent XLarge NEW	42	26595	20,9	75,2	20,4	-	25,4	27,1	-	25 (-1;-1)	Yes	Infinitely adjustable	2.8	650	50	80	20/24/28/32/36/40/44*	natural colour / RAL / dual colour	3000
Sonovent [®] XSmall 10	44	18416	14,5	52,1	20,4	74,5	19,1	23,6	10000	36 (-1;-1)	No	Infinitely adjustable	2.8	1200	-	130/135	20/24/28/32/36/40/44**	RAL / dual colour	2000/2500***
Sonovent [®] XSmall 15	44	30693	24,1	86,8	34,1	122,7	30,4	29,4	11000	31 (0;0)	No	Infinitely adjustable	2.8	1200	-	130/135	20/24/28/32/36/40/44**	RAL / dual colour	2000/2500***
Sonovent [®] XSmall 20	44	32995	25,9	93,3	36,9	132,8	29,5	30,1	18900	32 (-1;-1)	No	Infinitely adjustable	2.8	1200	-	130/135	20/24/28/32/36/40/44**	RAL / dual colour	2000/2500***
Sonovent [®] XSmall 25	44	35041	27,5	99,1	39,2	141,1	29,9	28,0	22300	31 (-1;-1)	No	Infinitely adjustable	2.8	1200	-	130/135	20/24/28/32/36/40/44**	RAL / dual colour	2000/2500***
Sonovent [®] Small 10	44	18324	14,4	51,8	20,6	74,2	19,1	23,6	10000	41 (-1;-2)	No	Infinitely adjustable	2.8	1200	-	130/135	20/24/28/32/36/40/44**	RAL / dual colour	2000/2500***
Sonovent [®] Small 15	44	30540	25,8	86,4	33,9	122,0	30,4	29,4	11000	36 (0;-1)	No	Infinitely adjustable	2.8	1200	-	130/135	20/24/28/32/36/40/44**	RAL / dual colour	2000/2500***
Sonovent [®] Small 20	44	32831	27,4	92,9	36,7	132,1	29,5	30,1	18900	35 (0;-1)	No	Infinitely adjustable	2.8	1200	-	130/135	20/24/28/32/36/40/44**	RAL / dual colour	2000/2500***
Sonovent [®] Small 25	44	34867	26,6	98,6	39,0	140,4	29,9	28,0	22300	34 (0;-2)	No	Infinitely adjustable	2.8	1200	-	130/135	20/24/28/32/36/40/44**	RAL / dual colour	2000/2500***
Sonovent [®] Medium 10	44	18070	14,2	51,1	20,7	74,5	18,1	14,7	10000	44 (-1;-4)	No	Infinitely adjustable	2.8	1200	-	130/135	20/24/28/32/36/40/44**	RAL / dual colour	2000/2500***
Sonovent [®] Medium 15	44	27359	21,5	77,4	30,8	110,9	26,9	21,9	11000	41 (0;-3)	No	Infinitely adjustable	2.8	1200	-	130/135	20/24/28/32/36/40/44**	RAL / dual colour	2000/2500***
Sonovent [®] Medium 20	44	34258	27,0	97,2	38,2	137,5	33,3	27,2	18900	39 (-1;-3)	No	Infinitely adjustable	2.8	1200	-	130/135	20/24/28/32/36/40/44**	RAL / dual colour	2000/2500***
Sonovent [®] Medium 25	44	35121	27,6	99,4	39,4	141,8	32,8	27,5	22300	37 (0;-3)	No	Infinitely adjustable	2.8	1200	-	130/135	20/24/28/32/36/40/44**	RAL / dual colour	2000/2500***
Sonovent [®] Large 10	44	16670	13,1	47,2	18,8	67,7	16,4	13,4	10000	46 (-1;-5)	No	Infinitely adjustable	2.8	1200	-	130/135	20/24/28/32/36/40/44**	RAL / dual colour	2000/2500***
Sonovent [®] Large 15	44	26341	20,7	74,5	29,5	106,2	25,7	32,0	11000	45 (-1;-4)	No	Infinitely adjustable	2.8	1200	-	130/135	20/24/28/32/36/40/44**	RAL / dual colour	2000/2500***
Sonovent [®] Large 20	44	33085	26,0	93,6	37,0	133,2	32,3	26,4	18900	41 (-1;-3)	No	Infinitely adjustable	2.8	1200	-	130/135	20/24/28/32/36/40/44**	RAL / dual colour	2000/2500***
Sonovent [®] Large 25	44	34485	27,1	97,6	38,6	139,0	29,6	25,8	22300	40 (-1;-4)	No	Infinitely adjustable	2.8	1200	-	130/135	20/24/28/32/36/40/44**	RAL / dual colour	2000/2500***
Sonovent [®] XLarge 10	44	14888	11,7	42,1	16,8	60,5	14,7	12,0	10000	48 (-1;-3)	No	Infinitely adjustable	2.8	1200	-	130/135	20/24/28/32/36/40/44**	RAL / dual colour	2000/2500***
Sonovent [®] XLarge 15	44	22269	17,5	63,0	24,7	88,9	21,5	17,6	11000	47 (-1;-5)	No	Infinitely adjustable	2.8	1200	-	130/135	20/24/28/32/36/40/44**	RAL / dual colour	2000/2500***
Sonovent [®] XLarge 20	44	32067	25,2	90,7	35,7	128,5	31,1	25,4	18900	43 (-1;-4)	No	Infinitely adjustable	2.8	1200	-	130/135	20/24/28/32/36/40/44**	RAL / dual colour	2000/2500***
Sonovent [®] XLarge 25	44	33721	26,5	95,4	37,8	136,1	33,0	26,9	22300	41 (-1;-4)	No	Infinitely adjustable	2.8	1200	-	130/135	20/24/28/32/36/40/44**	RAL / dual colour	2000/2500***
Sonovent [®] Compact 10	48	15334	12,1	43,4	16,4	58,9	17,3	17,8	9500	36 (0;-1)	No	Infinitely adjustable	3.45	650	150	78	20/24/28/32/36	RAL / dual colour	2000/2500***
Sonovent [®] Compact 13	48	19278	15,2	54,5	18,8	67,7	18,8	18,7	12500	35 (0;-1)	No	Infinitely adjustable	3.45	650	150	78	20/24/28/32/36	RAL / dual colour	2000/2500***
Sonovent [®] Compact 15	48	24687	19,4	69,8	19,9	71,5	18,6	19,1	15000	33 (0;-1)	No	Infinitely adjustable	3.45	650	150	78	20/24/28/32/36	RAL / dual colour	2000/2500***
Window vents for roller shutter boxes																			
Transivent [®]	52	13748	10,8	38,9	15,2	54,6	20,1	19,9	16368	28 (-1;-2)	Yes	5 positions	3.0	650	150	n/a	n/a	natural colour / RAL	2200 (1500 mm with cord control)
Sliding vents																			
THL100	56	16759	13,2	47,4	18,7	67,2	41,6	58,9	16200	22 (0;0)	No	Infinitely adjustable	3.9	400	n/a	129	15*/20/24/28	natural colour / RAL / dual colour	3500
THL100V	56	12770	10,0	36,1	14,2	51,3	32,1	45,5	27950	22 (0;0)	No	Infinitely adjustable	3.9	n/a	n/a	129	15*/20/24/28	natural colour / RAL / dual colour	3500
T100	58	17326	13,6	49,0	19,5	70,3	43,8	61,9	25342	n/a	No	Infinitely adjustable	n/a	n/a	n/a	n/a	n/a	natural colour / RAL / dual colour	3500
T130	58	24589	19,3	69,6	27,7	99,8	62,1	87,9	38302	n/a	No	Infinitely adjustable	n/a	n/a	n/a	n/a	n/a	natural colour / RAL / dual colour	3500
T150	58	27992	22,0	79,2	31,9	114,8	71,5	101,0	45592	n/a	No	Infinitely adjustable	n/a	n/a	n/a	n/a	n/a	natural colour / RAL / dual colour	3500
Slotvents																			
Sonoslot [®] , 275 mm	62	1273	1,0	3,6	1,4	5,0	3,2	3,3	1256	38 (0;0)	yes	Infinitely adjustable	1,4	n.a.	n.a.	n.a.	n.a.	anodised / Renson standard WHITE, 9005, 1247	275
Sonoslot [®] , 375 mm	62	1607	1,3	4,5	1,7	6,2	4,0	4,2	1885	37 (0;0)	yes	Infinitely adjustable	1,4	n.a.	n.a.	n.a.	n.a.	anodised / Renson standard WHITE, 9005, 1247	375
Sonoslot [®] , 475 mm	62	2121	1,7	6,0	2,3	8,3	5,3	5,6	2513	36 (0;0)	yes	Infinitely adjustable	1,4	n.a.	n.a.	n.a.	n.a.	anodised / Renson standard WHITE, 9005, 1247	475
Sonoslot [®] , 700 mm	62	3181	2,5	9,0	3,4	12,4	8,0	8,4	3769	34 (0;0)	yes	Infinitely adjustable	1,4	n.a.	n.a.	n.a.	n.a.	anodised / Renson standard WHITE, 9005, 1247	700
Sonoslot [®] Max without damping	64	2298	1,8	6,5	2,7	9,7	6,8	6,9	1871	38 (-1;-2)	no	no	-	n.a.	n.a.	n.a.	n.a.	Renson standard WHITE / RAL 1247	700
Sonoslot [®] Max with damping	64	1555	1,2	4,4	1,9	6,8	5,1	7,6	1871	40 (-1;-2)	no	no	-	n.a.	n.a.	n.a.	n.a.	Renson standard WHITE / RAL 1247	700
Pyramid 2500	66	2723	2,1	7,6	3,1	10,85	7,0	10,1	2200	36 (0;0)	no	no	-	n.a.	n.a.	n.a.	n.a.	anodised / Renson standard WHITE, 9005, 7016	n.a.
Pyramid 5000	66	5229	4,2	15,1	6,0	21,6	13,6	19,4	4590	33 (-1;0)	no	no	-	n.a.	n.a.	n.a.	n.a.	anodised / Renson standard WHITE, 9005, 7016	n.a.
Pyracoust 2500 + 1 acoustic module	68	2749	2,2	7,9	3,2	11,5	7,6	11,1	2496	42 (-1;-2)	no	no	-	n.a.	n.a.	n.a.	n.a.	anodised / Renson standard WHITE, 9005, 7016	n.a.
Pyracoust 2500 + 2 acoustic modules	68	2736	2,2	7,9	3,1	11,2	7,5	11,0	2496	45 (-2;-3)	no	no	-	n.a.	n.a.	n.a.	n.a.	anodised / Renson standard WHITE, 9005, 7016	n.a.
Pyracoust 5000 + 1 acoustic module	68	5714	4,5																

WHY VENTILATE?

! TO MEASURE IS TO KNOW



In a properly insulated home without ventilation, we constantly breathe in polluted air. Unfortunately, we lack the ability to see or smell whether the air we breathe is dirty or not. For that exact reason, a reliable monitor is an indispensable tool when it comes to taking action in good time when the air quality is deteriorating. Renson Sense is so much more than a traditional CO₂ monitor. Our device also monitors the humidity level, volatile organic compounds (VOCs) and other parameters such as odours, noise, temperature and light. **More information: www.renson.net**

1

BREATHING HEALTHY AIR

The air quality in a home is generally significantly worse than the air quality outside. Cooking, showering, heating, cleaning and even breathing and sweating are all factors that pollute the air. With adequate ventilation, you can rest assured you are breathing healthy air inside.

2

GOOD FOR OCCUPANTS AND THE HOME

Good indoor air quality matters as much to the building itself as it does to the health of its occupants. Ventilation prevents damp from forming, offering protection against the associated risks such as mould and damage to the interior.

3

SAVE ENERGY

Did you know that humid and polluted air heats up more slowly? Adequate ventilation keeps the air in your home clean and dry. As a direct consequence, this results in lower heating costs and lower energy bills.

REGULATIONS

Brief guide to UK building regulations, part F - ventilation

Domestic buildings

NEW BUILDINGS (WITH ANY DESIGN AIR PERMEABILITY)

Previously ventilation area was shown in free area mm² whereas now it is calculated and shown as Equivalent Area (EA) per mm² as in the table shown below based upon 2 occupants in the main bedroom and a single occupant in all other bedrooms.

Total floor area (m ²)	Number of bedrooms				
	1	2	3	4	5
< 50	35000	40000	50000	60000	65000
51 – 60	35000	40000	50000	60000	65000
61 – 70	45000	45000	50000	60000	65000
71 – 80	50000	50000	50000	60000	65000
81 – 90	55000	60000	60000	60000	65000
91 – 100	65000	65000	65000	65000	65000
> 100	add 7000 mm ² for every additional 10 m ² floor area				

The minimum equivalent area (EA) for habitable rooms is 5000 mm² EA and for any wet room 2500 mm² EA.

Please contact Renson UK for more information regarding basements, habitable rooms with non opening windows, modular or portable buildings and acoustic needs for buildings.

EXISTING BUILDINGS

Where renovations are being carried out to an existing building then the background ventilation should not be smaller than originally provided, but it must be at least 5000 mm² EA for habitable rooms and 2500 mm² EA for wet rooms.

Please contact Renson UK for more information regarding connecting to a conservatory, addition of a wet room or addition of a habitable room.

Non-domestic buildings

NEW OFFICES

10 l/s (litres per second) per person of air supply is needed

EXISTING OFFICES, HOTELS, ...

Floor area under 10 m ²	-	2500 mm ² EA
Floor area over 10 m ²	-	250 mm ² /m ² EA
Kitchens	-	2500 mm ² EA
Bathrooms/showers/WC	-	2500 mm ² EA per bath, shower or toilet

NEW SCHOOLS (ACCORDING TO BUILDING BULLETIN 101)

8 l/s (litres per second) per person of air supply is needed.





I-FLUX[®] TECHNOLOGY

Maximal comfort, minimum energy loss!

OUR I-FLUX TECHNOLOGY IS BASED ON THE FOLLOWING PRINCIPLES:

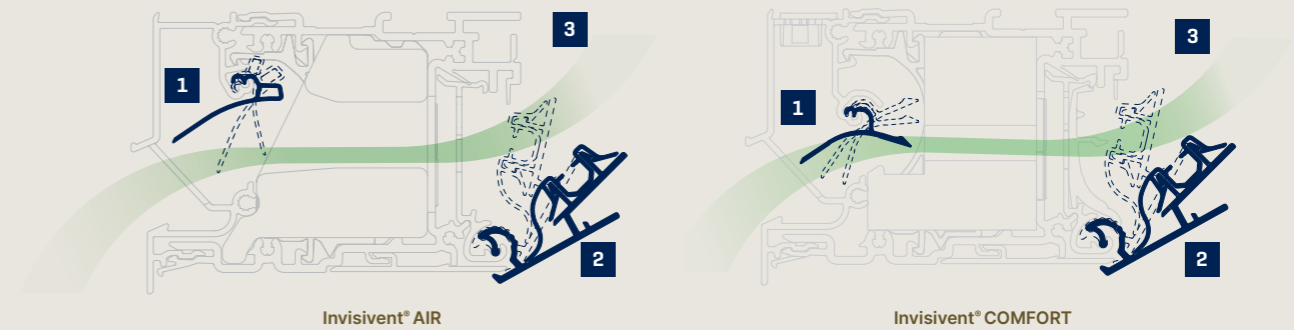

1. Air Airflow independent of the wind

The use of a self-regulating valve that reacts to changes in pressure makes it possible to maintain a constant air Airflow even in gusts of wind, all while keeping out draughts. Self-regulation is expressed in different ratings, from P0 (no self-regulation) to P4 (excellent self-regulation).

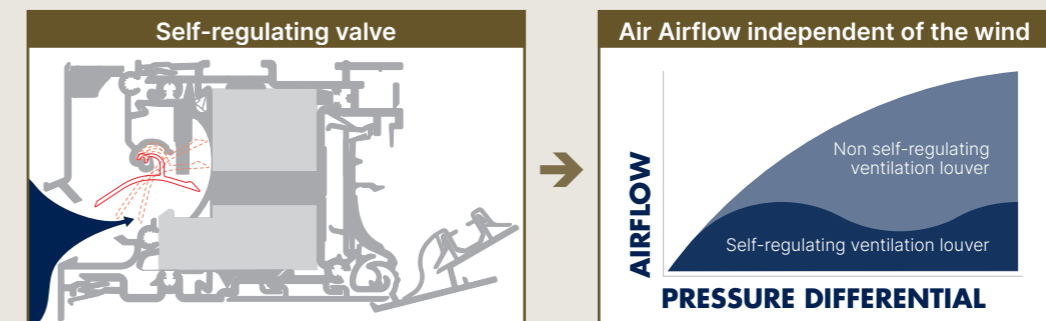

2. Air Airflow can be controlled using manually adjustable inner valve

The user can set the desired Airflow depending on how many occupants are in the room, for example.

3. Upward air flow for optimum comfort

The shape of the inner valve conducts the fresh air upwards, leading to optimal air distribution throughout the room and guaranteeing maximal comfort.

SUPPORT FROM A TO Z

We are here for you (and your team)! In need of training?
Technical assistance or an intervention at the construction site?

SUPPORT

INTRO

One phone call to the **HOTLINE** was enough to get my team back on track at the construction site. We promptly got the technical information we were looking for. Perfect service that saved a lot of time!



Hotline

Not sure which solution is the best answer? Struggling with a specific technical issue at the construction site? Contact one of our distribution partners or call a Renson helpdesk representative via the **HOTLINE** on +32 (0)56 30 30 30. If necessary, we will even send a Renson technician to your site. This will save you lots of time and give you a lot less to worry about!

Renson Academy

Perfectly functioning sun protection starts with correct installation. Good product knowledge and technical skills will save you a lot of time. You (and your team) are welcome to join us for:

- An update of your product knowledge
- A refresher of your skills
- Learning new techniques

? RENSON & ORGADATA

The Renson Invisivent database - including all options - is available in Orgadata for both Logikal and ReynaPro users. Thus, as a window designer, you can now easily add these window vents to all possible digital models. In addition to a clear visualisation, you can immediately see the correct dimensions in function of the deduction dimension and a U-value calculation.

ORGADATA

! RENSON.NET

Customers will find lots of information about our products on our website. Moreover, on our Professionals portal, you will find all technical information such as manuals, technical data sheets, ecolabel, brochures for your customers, specification sheets, and more. If you have trouble finding what you're looking for right away, please get in touch with our **HOTLINE**.

! Renson Academy On Tour

Limited in time? Distance too great? Our Academy is happy to come to you. In need of a tailored training course? Not a problem. Putting theory straight into practice will help you move forward! We would love to hear how we can support you. Register at:
renson.net > I'm a professional > Training



WHY RENSON?

At Renson, we believe that high-quality products and innovative solutions contribute to an energy-efficient, comfortable and healthy life. There is a reason why our baseline is 'Creating healthy spaces'. And in doing so, we start from a few basic principles.



MINIMALIST DESIGN

We aim high when it comes to design. Renson solutions discretely fit into any project. The detailed finishing and seamless integration contribute to this fact.



THE POWER OF INNOVATION

Our hunger for innovation is what drives progress. We achieve impressive results together by developing and applying innovative technologies.



ENDLESS CUSTOMISATION OPTIONS

For your home or workspace, rustic or contemporary. Configuring a solution tailored to each customer and building is quick and easy.



SUSTAINABLE ENTREPRENEURSHIP

We cannot build a healthy living environment without tending to a healthy world. From our choice of materials to our production and logistics, we are building a sustainable business.



ULTIMATE EASE OF USE AND MAINTENANCE

Thorough engineering is a function of ease of use and minimum maintenance. From configuration and ordering to quick and trouble-free installation, with our digital platform, RIO, as its beating heart.



OVERVIEW PRODUCTS

Overframe window vents

Invisivent® AIR	20
Invisivent® COMFORT	24
Invisivent® options	30

Flap ventilators glazed-in/at transom

Thermally interrupted	
TC60	34
AR60	36
AR90	38
THM90	40
Variavent <small>NEW</small>	42

Thermally interrupted and soundproofed	
Sonovent®	44
Sonovent® Compact	48

Roller shutter flap ventilator

Transivent®	52
-------------	----

Sliding vents

THL100 - THL100V	56
T100 - T130 - T150	58

Slotvents

Sonoslot®	62
Sonoslot® Max	64
Pyramid	66
PyrAcoust	68
Interior slotvents	70
Exterior slotvents	71

Combined ventilation and Sun Protection overframe

Fixivent® Mono AK	74
Fixivent® Mono UT	78

OVERFRAME WINDOW VENTS

Our Invisivent window vent is an acoustic, thermal, and energy-efficient window vent that can easily be used in any project, be it a newbuild or renovation project.

This product is designed in accordance with the monobloc principle, which means that it can be anchored to the window profile as a single, stable unit. On top of that, Invisivent can always be combined with an optional design cap. This provides additional protection against water and wind load, while also delivering added value aesthetically, as an Invisivent window vent with a design cap can be concealed easily and entirely behind the brickwork (rendering it completely invisible). What's more, Renson offers a "High Rise" solution which is ideal for applications impacted by wind, such as high-rise buildings and apartment blocks on the coast.

INVISIVENT AIR VS COMFORT

Our Invisivent window vent is available in two versions: Air and Comfort. Invisivent Comfort goes one step beyond Invisivent Air by guaranteeing even higher acoustic damping and even greater thermal and energetic comfort thanks to the integrated, self-regulating non-return valve. The Invisivent Comfort combined with an extraction point in the same room (Healthbox 3.0, SmartZone configuration) ensures optimum indoor air quality. Thus, energy losses and uncontrolled ventilation are avoided at all times.

INSTALLATION ON THE TOP OF THE WINDOW PROFILE

Invisivent window vent can be placed behind the brickwork, on the top of aluminium, wood or UPVC window profiles. As this window vent has no impact on the size of the windowpane, this near-invisible installation method guarantees you'll get the maximum amount of light coming in.

PERFECT AIRTIGHT CONNECTION TO WINDOW PROFILE

A coextruded rubber seal that runs the entire length of the window vent (including the end caps) provides a perfectly airtight connection between the Invisivent window vent and the window profile.



Invisivent® Air (page 20)



Invisivent® Comfort (page 24)

INVISIVENT® AIR



Discreet and energy-efficient window vents for a healthy and comfortable indoor climate

Even in their narrowest versions, our Invisivent AIR window vents are fitted with acoustic damping material as standard. An acoustic leak to the cavity ensures extra impressive acoustic performance.

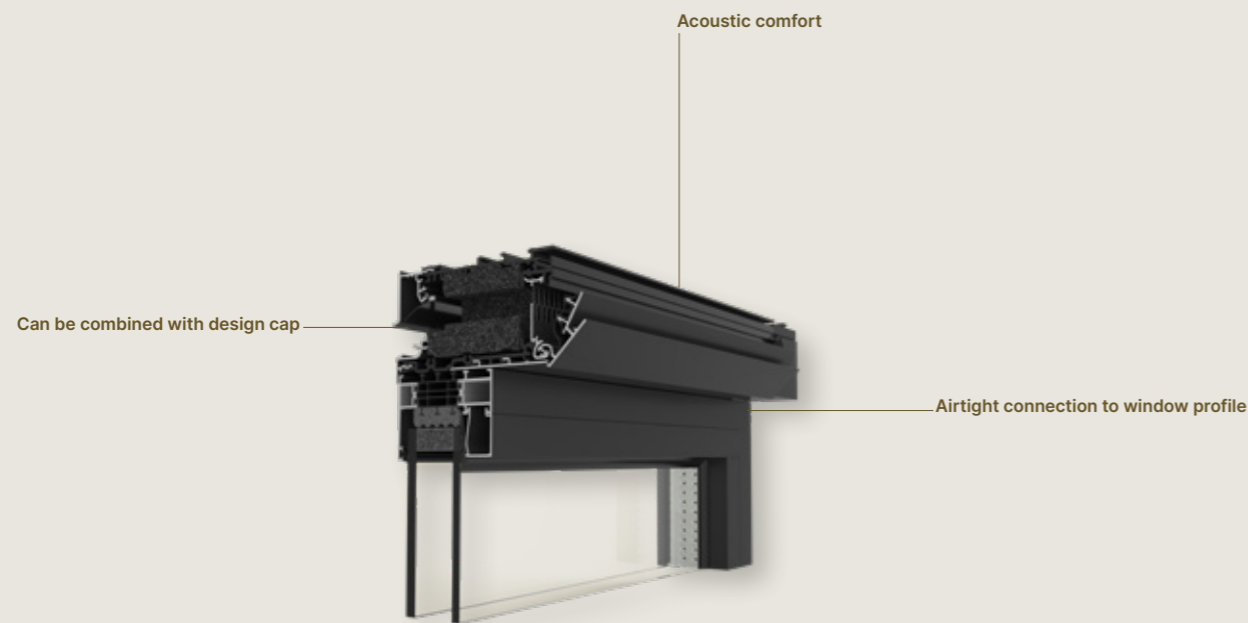

INVISIVENT® AIR LIGHT

Technical details	
Airflow	
Equivalent area	13479 mm ² /m
Q at 1 Pa	10.6 l/s/m
Q at 1 Pa	38.1 m ³ /h/m
Q at 2 Pa	17.2 l/s/m
Q at 2 Pa	62.0 m ³ /h/m
Q at 10 Pa	16.4 l/s/m
Q at 20 Pa	19.2 l/s/m
Sound reduction D_{n,e,w} (C;C_{tr})	
In open position	31 (-1;-2) dB
In closed position	51 (-1;-3) dB
Technical details	
Positions	5 positions
Controls	Cord, manual, motor, rod
U value	2.0 W/m ² K
Airflow at 50 Pa	<15% (in closed position)
Watertightness in closed position	Up to 900 Pa
Watertightness in open position	Up to 150 Pa - 250 Pa (with design cap)
Dimensions	
Glass reduction	0 mm
Height	65 mm
Window profile depth	50 - 202 mm (or deeper upon request)
Max. length	6000 mm



With design cap (optional)

OVERFRAME WINDOWVENTS

Technical properties	Invisivent AIR Light	Invisivent AIR Basic	Invisivent AIR High
I-Flux		✓	
With thermal break		✓	
Self-regulating		✓	
Acoustic comfort (open position)	31 (-1;-2) dB	34 (0;-1) dB	40 (0;-2) dB
Burglar-resistant	Class 2, suitable for WK2 windows		
Insect-proof		✓	
Non-residential application	Possible, see www.renson.net		

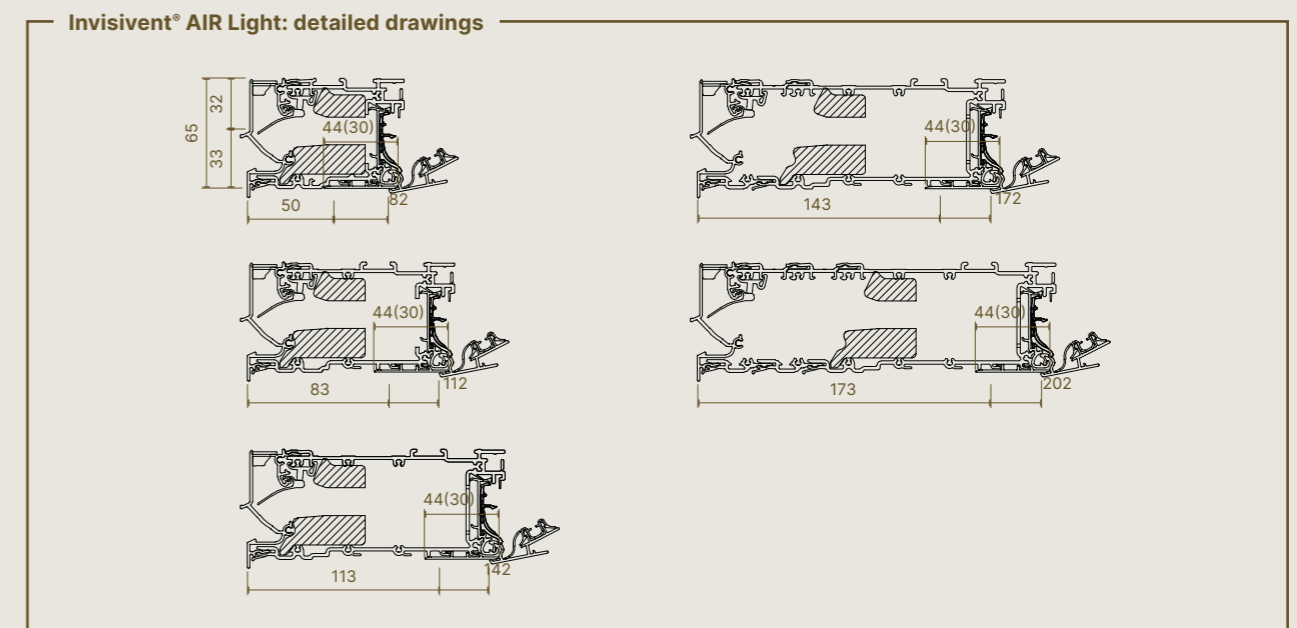

INVISIVENT® AIR BASIC

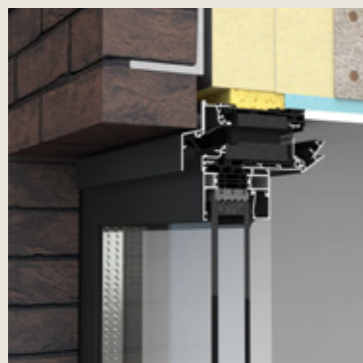

With design cap (optional)

Technical details						
Airflow						
Equivalent area	Q at 1 Pa	Q at 1 Pa	Q at 2 Pa	Q at 2 Pa	Q at 10 Pa	Q at 20 Pa
	l/s/m	m³/h/m	l/s/m	m³/h/m	l/s/m	l/s/m
13429 mm²/m	10.6	38.0	17.2	62.0	17.6	17.3
Sound reduction $D_{n,e,w}$ (C;C _{tr})						
In open position			34 (0;-1) dB			
In closed position			51 (-1;-3) dB			
Technical details						
Positions			5 positions			
<i>High-rise</i>			16 positions			
Controls			Cord, manual, motor, rod			
U value			1.8 W/m²K			
Airflow at 50 Pa			<15% (in closed position)			
Watertightness in closed position			Up to 900 Pa			
<i>High-rise</i>			Up to 1200 Pa			
Watertightness in open position			Up to 150 Pa - 250 Pa (with design cap)			
<i>High-rise</i>			Up to 250 Pa			
Dimensions						
Glass reduction			0 mm			
Height			65 mm			
<i>High-rise</i>			66.5 mm			
Window profile depth			50 - 202 mm (or deeper upon request)			
Max. length			6000 mm			

INVISIVENT® AIR HIGH



With design cap (optional)

Technical details						
Airflow						
Equivalent area	Q at 1 Pa	Q at 1 Pa	Q at 2 Pa	Q at 2 Pa	Q at 10 Pa	Q at 20 Pa
	l/s/m	m³/h/m	l/s/m	m³/h/m	l/s/m	l/s/m
11364 mm²/m	8.9	32.2	12.1	43.4	11.9	14.3
Sound reduction $D_{n,e,w}$ (C;C _{tr})						
In open position			40 (0;-2) dB			
In closed position			51 (-1;-3) dB			
Technical details						
Positions			5 positions			
<i>High-rise</i>			16 positions			
Controls			Cord, manual, motor, rod			
U value			1.8 W/m²K			
Airflow at 50 Pa			<15% (in closed position)			
Watertightness in closed position			Up to 900 Pa			
<i>High-rise</i>			Up to 1200 Pa			
Watertightness in open position			Up to 150 Pa - 250 Pa (with design cap)			
<i>High-rise</i>			Up to 250 Pa			
Dimensions						
Glass reduction			0 mm			
Height			65 mm			
<i>High-rise</i>			66.5 mm			
Window profile depth			50 - 202 mm (or deeper upon request)			
Max. length			6000 mm			

Invisivent® AIR Basic: detailed drawings

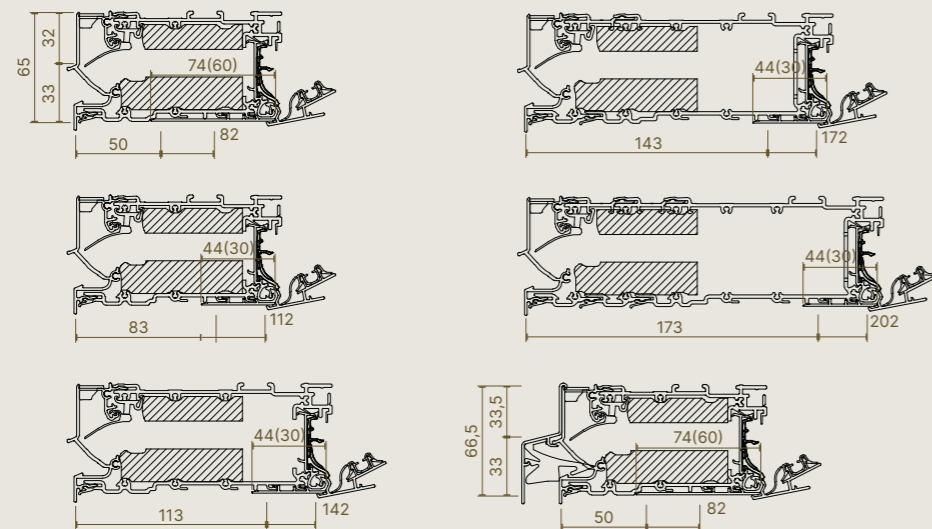

AIR Basic with optional high-rise version

Invisivent® AIR High: detailed drawings

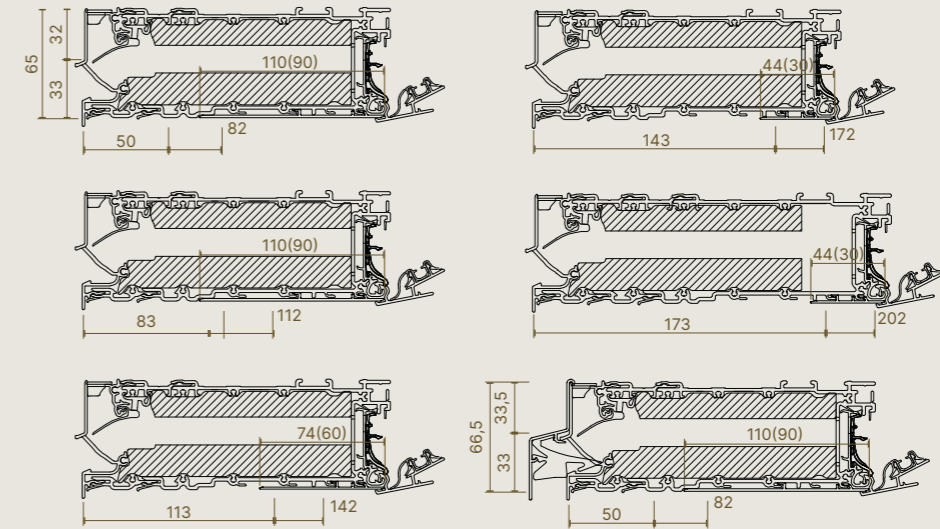

AIR High with optional high-rise version

INVISIVENT® COMFORT



The ultimate comfort in natural ventilation

Even in their narrowest versions, our Invisivent Comfort window vents are fitted with acoustic damping material as standard. An acoustic leak to the cavity ensures extra impressive acoustic performance.

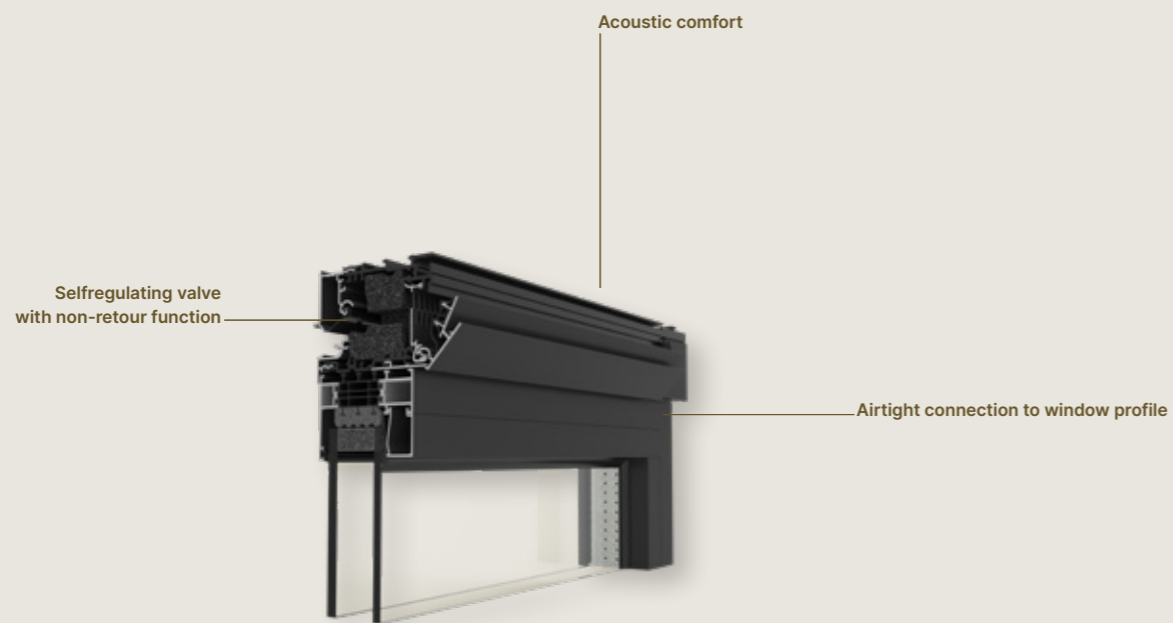

INVISIVENT® COMFORT BASIC

Technical details						
Airflow						
Equivalent area	Q at 1 Pa	Q at 1 Pa	Q at 2 Pa	Q at 2 Pa	Q at 10 Pa	Q at 20 Pa
	l/s/m	m³/h/m	l/s/m	m³/h/m	l/s/m	l/s/m
4311 mm²/m	3.4	12.2	6.0	21.6	18.8	24.0
Sound reduction $D_{n,e,w}$ ($C; C_{tr}$)						
In open position	35 (-1;-2) dB					
In closed position	51 (-1;-3) dB					
Technical details						
Positions	5 positions					
<i>High-rise</i>	16 positions					
Controls	Cord, manual, motor, rod					
U value	1.8 W/m²K					
Airflow at 50 Pa	<15% (in closed position)					
Watertightness in closed position	Up to 900 Pa					
<i>High-rise</i>	Up to 1200 Pa					
Watertightness in open position	Up to 150 Pa - 250 Pa (with design cap)					
<i>High-rise</i>	Up to 250 Pa					
Dimensions						
Glass reduction	0 mm					
Height	65 mm					
<i>High-rise</i>	66.5 mm					
Window profile depth	50 - 202 mm (or deeper upon request)					
Max. length	6000 mm					



With design cap (optional)

OVERFRAME WINDOWVENTS

Technical properties	Invisivent Comfort Basic	Invisivent Comfort High	Invisivent Comfort Ultra
I-Flux	✓ (self-regulating from 10 Pa and with non-return valve)		
With thermal break		✓	
Self-regulating		✓	
Acoustic comfort (open position)	35 (-1;-2) dB	39 (0;-2) dB	42 (0;-2) dB
Burglar-resistant	Class 2, suitable for WK2 windows		
Insect-proof		✓	

Invisivent® Comfort Basic: detailed drawings

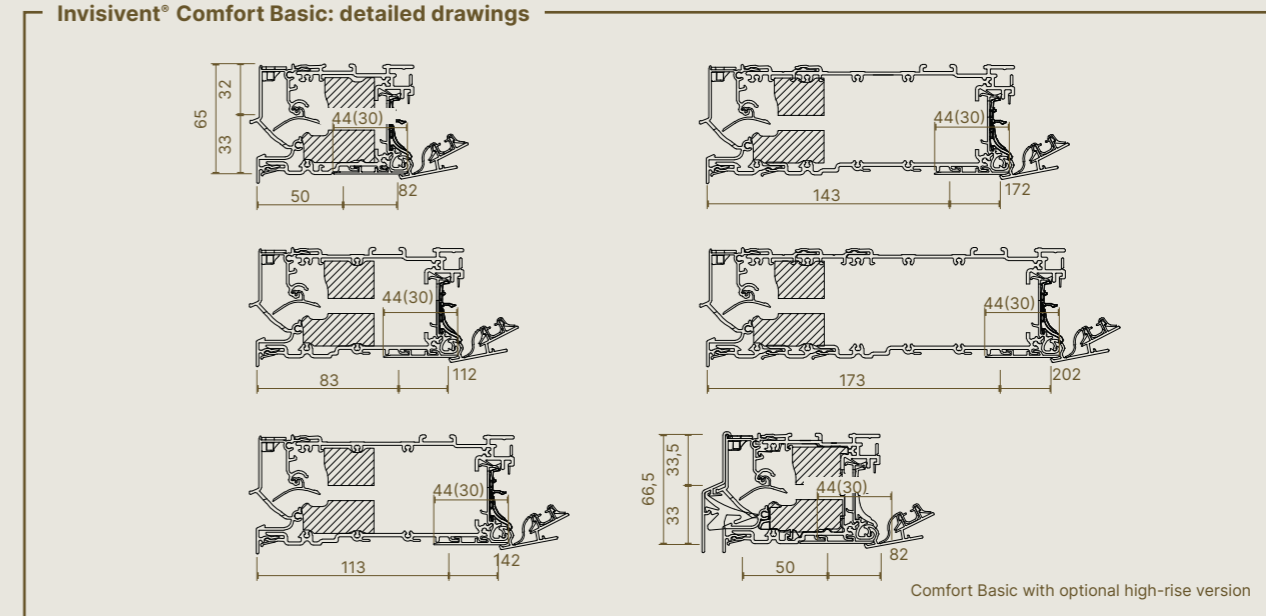

INVISIVENT® COMFORT HIGH

INVISIVENT® COMFORT ULTRA

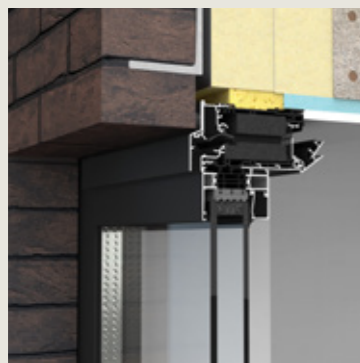

With design cap (optional)

Technical details						
Airflow						
Equivalent area	Q at 1 Pa	Q at 1 Pa	Q at 2 Pa	Q at 2 Pa	Q at 10 Pa	Q at 20 Pa
	l/s/m	m³/h/m	l/s/m	m³/h/m	l/s/m	l/s/m
2936 mm²/m	2.3	8.3	4.7	16.8	12.4	18.2
Sound reduction $D_{n,e,w}$ (C;C _{tr})						
In open position			39 (0;-2) dB			
In closed position			51 (-1;-3) dB			
Technical details						
Positions			5 positions			
<i>High-rise</i>			16 positions			
Controls			Cord, manual, motor, rod			
U value			1.8 W/m²K			
Airflow at 50 Pa			<15% (in closed position)			
Watertightness in closed position			Up to 900 Pa			
<i>High-rise</i>			Up to 1200 Pa			
Watertightness in open position			Up to 150 Pa - 250 Pa (with design cap)			
<i>High-rise</i>			Up to 250 Pa			
Dimensions						
Glass reduction			0 mm			
Height			65 mm			
<i>High-rise</i>			66.5 mm			
Window profile depth			50 - 202 mm (or deeper upon request)			
Max. length			6000 mm			



With design cap (optional)

Technical details						
Airflow						
Equivalent area	Q at 1 Pa	Q at 1 Pa	Q at 2 Pa	Q at 2 Pa	Q at 10 Pa	Q at 20 Pa
	l/s/m	m³/h/m	l/s/m	m³/h/m	l/s/m	l/s/m
2356 mm²/m	1.9	6.7	3.3	11.8	10.0	14.4
Sound reduction $D_{n,e,w}$ (C;C _{tr})						
In open position			42 (0;-2) dB			
In closed position			51 (-1;-3) dB			
Technical details						
Positions			5 positions			
<i>High-rise</i>			16 positions			
Controls			Cord, manual, motor, rod			
U value			1.7 W/m²K			
Airflow at 50 Pa			<15% (in closed position)			
Watertightness in closed position			Up to 900 Pa			
<i>High-rise</i>			Up to 1200 Pa			
Watertightness in open position			Up to 150 Pa - 250 Pa (with design cap)			
<i>High-rise</i>			Up to 250 Pa			
Dimensions						
Glass reduction			0 mm			
Height			65 mm			
<i>High-rise</i>			66.5 mm			
Window profile depth			50 - 202 mm (or deeper upon request)			
Max. length			6000 mm			

Invisivent® Comfort High: detailed drawings

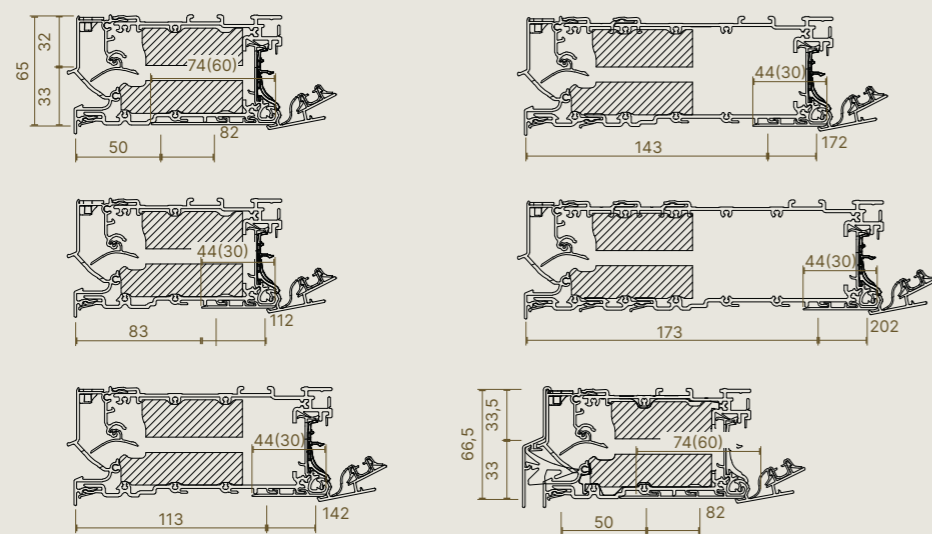

Comfort High with optional high-rise version

Invisivent® Comfort Ultra: detailed drawings

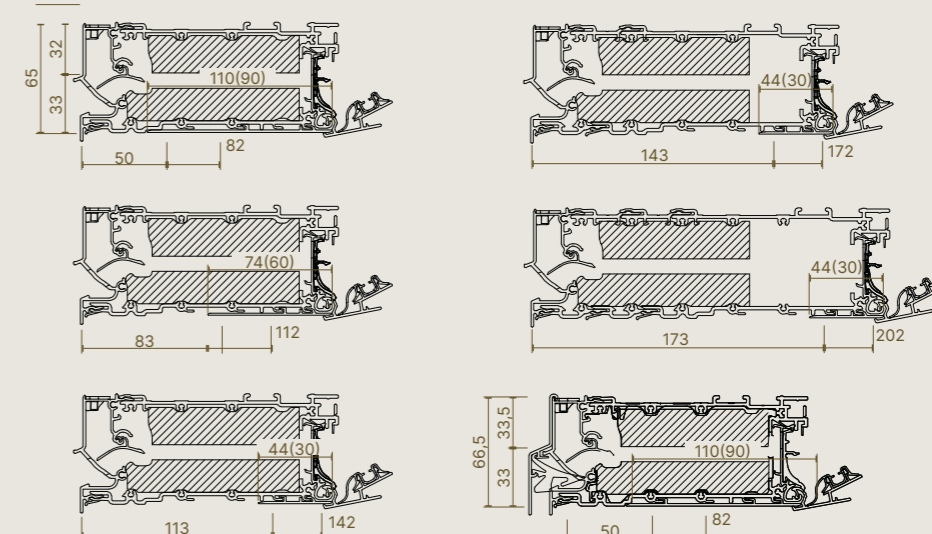

Comfort Ultra with optional high-rise version

INVISIVENT® COMFORT EXTREME



With design cap

Technical details						
Airflow						
Equivalent area	Q at 1 Pa	Q at 1 Pa	Q at 2 Pa	Q at 2 Pa	Q at 10 Pa	Q at 20 Pa
	l/s/m	m³/h/m	l/s/m	m³/h/m	l/s/m	l/s/m
213 mm²/m	0,2	0,6	0,8	2,9	4,4	6,2
Sound reduction $D_{n,e,w}$ (C;C _{tr})						
In open position			48 (0;-2) dB			
In closed position			62 (-1;-4) dB			
Technical details						
Positions			5 positions			
<i>High-rise</i>			16 positions			
Controls			Cord, manual, motor, rod			
U value			1.7 W/m²K			
Airflow at 50 Pa			<15% (in closed position)			
Watertightness in closed position			Up to 900 Pa			
<i>High-rise</i>			Up to 1200 Pa			
Watertightness in open position			Up to 250 Pa			
<i>High-rise</i>			Up to 250 Pa			
Dimensions						
Glass reduction			0 mm			
Height			66.5 mm			
<i>High-rise</i>			66.5 mm			
Window profile depth			50 - 202 mm (or deeper upon request)			
Max. length			6000 mm			

Invisivent® Comfort Extreme: detailed drawings

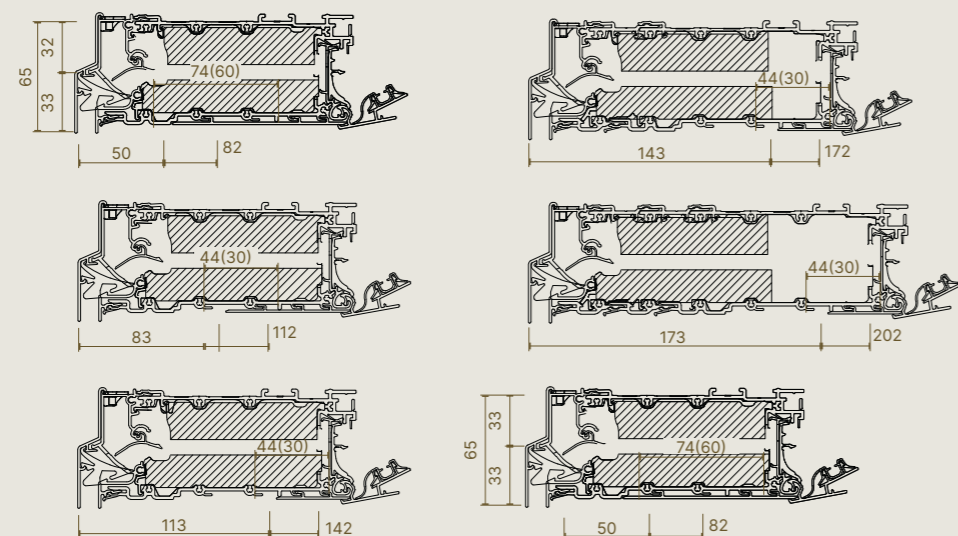

OVERFRAME WINDOWVENTS

INVISIVENT® OPTIONS

SPLIT INNER VALVE

For ease of use or if requested by a customer, the inner valve can be split for lengths in excess of 3000 mm. If so, a special mid piece (3 mm thick) is placed between the two valves to guarantee a neat finish.

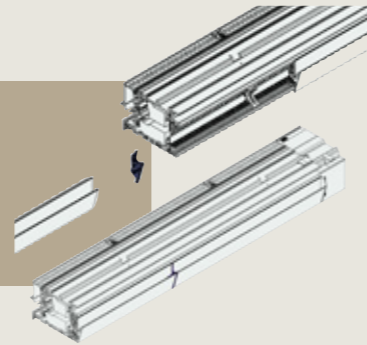

FINISHING PROFILE

The Invisivent AIR/COMFORT is designed to provide a perfect finish. There is a cut-out at the top of the vent that takes plasterboard or MDF panels up to 10 mm thick, and which allows the plasterer to integrate the vent discreetly into the plastered surface.

The optional aluminium finishing profile should be used with traditional wet plastering. The profile should also be used for a perfect finish when installing a roller shutter box, for example, above the Invisivent AIR/COMFORT. This profile is available in the same finish as the inside of the Invisivent AIR/COMFORT.

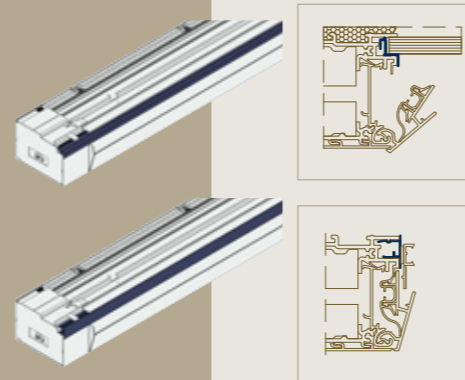

INSTALLATION USING WALL BRACKETS

The Invisivent AIR/COMFORT has a dowel slot so it can be attached quickly and easily to the unfinished structure by using wall brackets

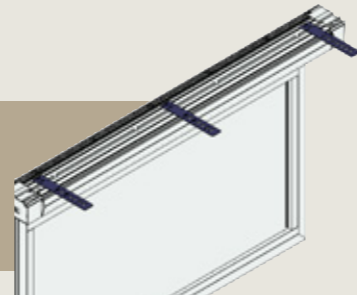

JOINING MULTIPLE INVISIVENT AIR/COMFORT

Invisivent AIR/COMFORT is available in lengths up to six metres. Even so, it is possible to place multiple Invisivent AIR/COMFORT next to each other, neatly finished with a coupling plate between the different window vents.

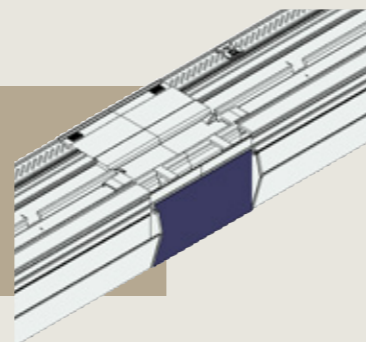

DESIGN CAP

If Invisivent AIR/COMFORT is to be exposed to harsh weather conditions (rain, sand, high wind loads,..), you can choose to have a design cap fitted to the product. This cover guarantees optimal comfort, even in extreme weather conditions.

Each high rise version is equipped standard with a design cap. Additional clips guarantee that the inner valve operates with the perfect closing force. Each high rise model contains acoustic material that dampens external noises to the greatest extent possible, resulting in increased user comfort. The high rise version is available in 6 different sound-damping levels

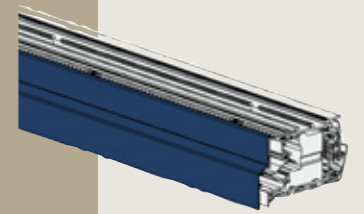

SIDE MOUNTING PLATE

The side plate provides an aesthetic finish to the Invisivent when the side of the Invisivent is visible.

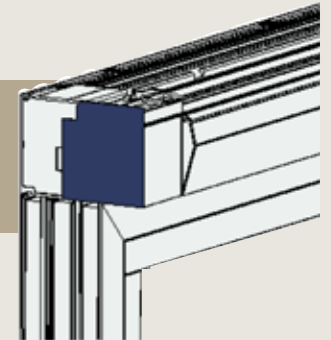

AIRFLOW LIMITERS

Airflow limiters can easily be clipped into the Invisivent AIR and COMFORT. They close the opening by 100 mm so that the maximum flow can be adjusted to suit your needs. When split in half, each section can be used to seal off 50 mm of the supply opening. These restrictors serve as the perfect way to control the maximum air flow.

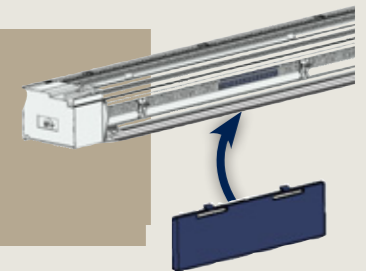

REPLACEABLE ACOUSTIC FOAM

Thanks to the perforations in the PVC middle profile, the acoustic foam in Invisivent AIR and Invisivent COMFORT can easily be removed from the window vent for easy cleaning or replacement.

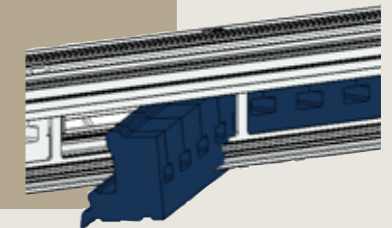

POLLUX®: OPTIONAL FINE DUST AND POLLEN FILTER

For fine dust-loaded environments, a Pollux type O4 filter can optionally be added to the Invisivent AIR/COMFORT.

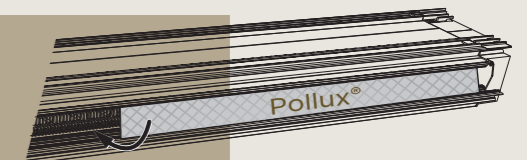



FLAP VENTILATORS GLAZED-IN/AT TRANSOM

This window vent type has been designed for glazed-in installation and can be integrated into aluminium, wood and UPVC window frames. These vents can also be placed at transom using an additional transom profile.

Thermally interrupted

TC60	34
AR60	36
AR90	38
THM90 ^{EVO}	40
Variavent® <small>NEW</small>	42

Thermally interrupted and sound-absorbing

Sonovent®	44
Sonovent® Compact	48

TC60

Compact window vent with an excellent price-quality ratio

TC60 is a non-self-regulating, aluminium window vent with a thermal break for glazed-in installation. What sets TC60 apart is the slightly sloping design of its outer profile and its glass reduction of just 60 mm.

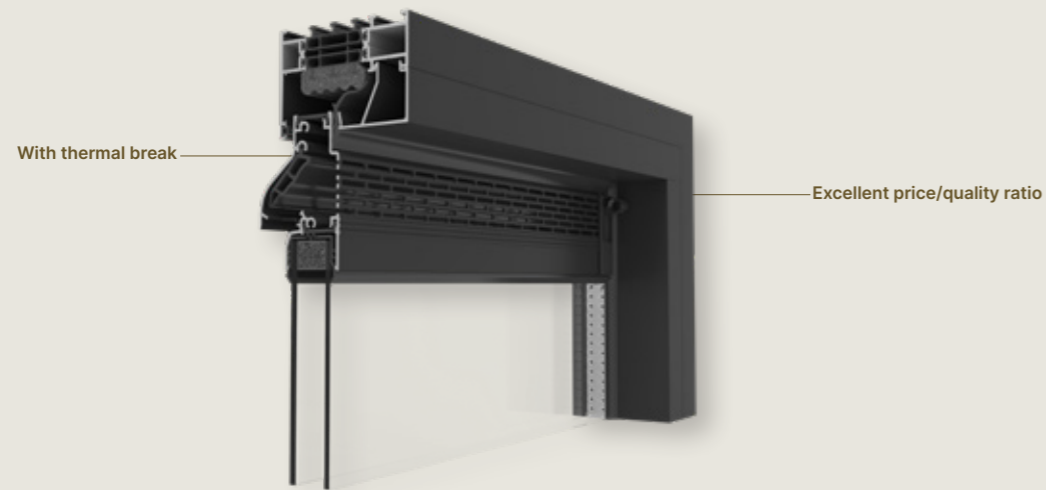

Technical properties	
Installation at transom	✓
With thermal break	✓
Self-regulating	-
Flat inner profile	✓
Insect-proof	✓

Technical details	
Airflow	
Equivalent area	15652 mm ² /m
Q at 1 Pa	12.3 l/s/m
Q at 1 Pa	44.3 m ³ /h/m
Q at 2 Pa	17.4 l/s/m
Q at 10 Pa	38.9 l/s/m
Q at 20 Pa	55.0 l/s/m
Sound reduction D_{n,e,w} (C;C_{tr})	
In open position	28 (0;0) dB
In closed position	42 (0;0) dB
Technical details	
Positions	Infinitely adjustable
Controls	Cord, manual, rod
U value	3.3 W/m ² K
Airflow at 50 Pa	<15% (in closed position)
Watertightness in closed position	Up to 650 Pa
Watertightness in open position	Up to 10 Pa
Dimensions	
Glass reduction	60 mm
Height	76 mm
Glass thickness	20, 24 or 28 mm
Max. length	2000 mm



FLAP VENTILATORS
GLAZED-IN/AT TRANSOM

Detailed drawings

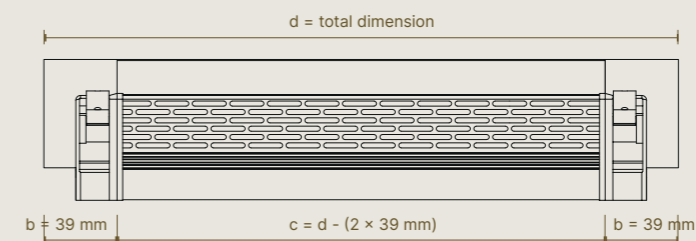
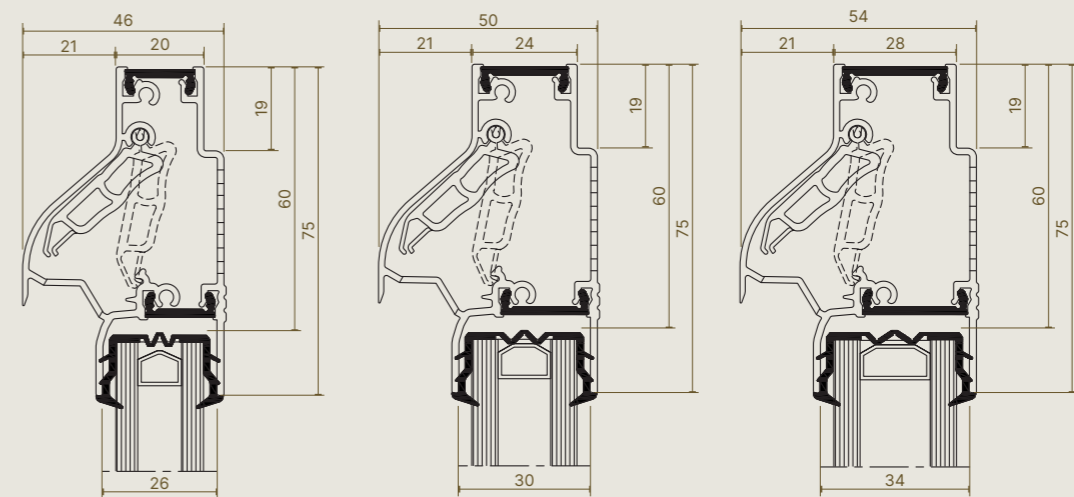

d = total dimension c = profile = cut size

AR60

Self-regulating window vent

What sets AR60 apart is its curved inner profile that directs the incoming air flow upwards. On the outside, AR60 comes with a rain protection cover. The self-regulating valve prevents draughts and helps to minimise energy loss.

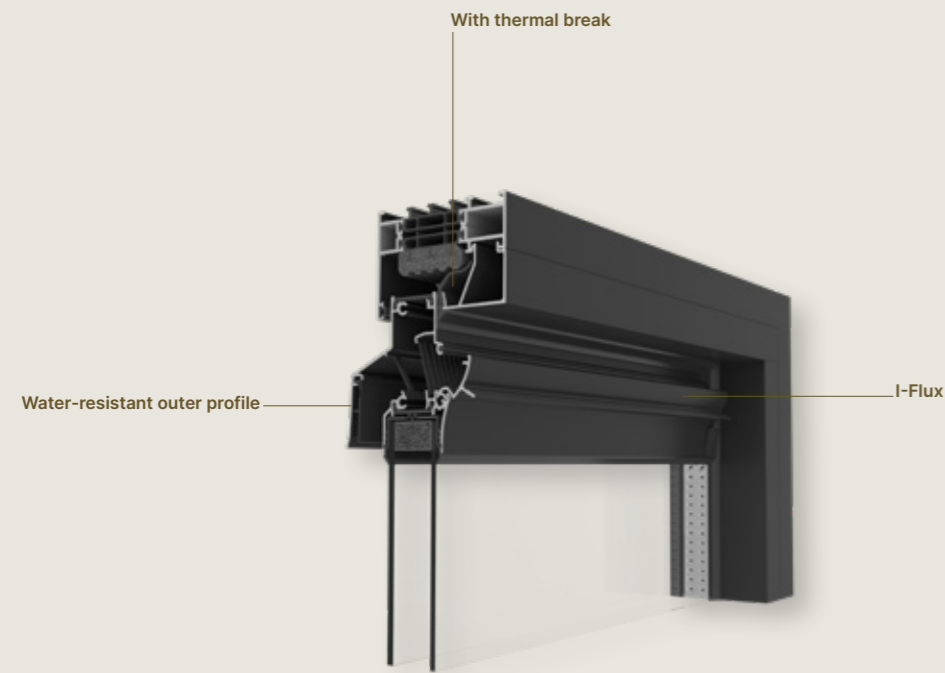

Technical details	
Airflow	
Equivalent area	10427 mm ²
Q at 1 Pa	8,2 l/s/m
Q at 1 Pa	29,5 m ³ /h/m
Q at 2 Pa	11,8 l/s/m
Q at 10 Pa	19,7 l/s/m
Q at 20 Pa	23,9 l/s/m
Sound reduction D_{n,e,w} (C;C_{tr})	
In open position	27 (0;0) dB
In closed position	44 (0;0) dB
Technical details	
Positions	5 positions
Controls	Cord, manual, rod
U value	4.5 W/m ² K
Airflow at 50 Pa	<15% (in closed position)
Watertightness in closed position	Up to 650 Pa
Watertightness in open position	Up to 100 Pa
Dimensions	
Glass reduction	60 mm
Height	76 mm
Glass thickness	20, 24 or 28 mm
Max. length	3500 mm

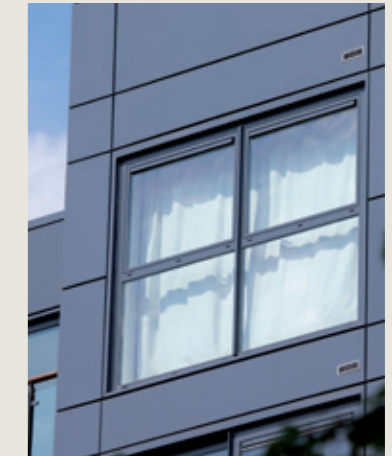

FLAP VENTILATORS
GLAZED-IN/AT TRANSOM

Technical properties	
Installation at transom	✓
With thermal break	✓
Self-regulating	✓
I-Flux	Fresh air supply without draughts, manually adjustable
Flat inner profile	-
Insect-proof	✓

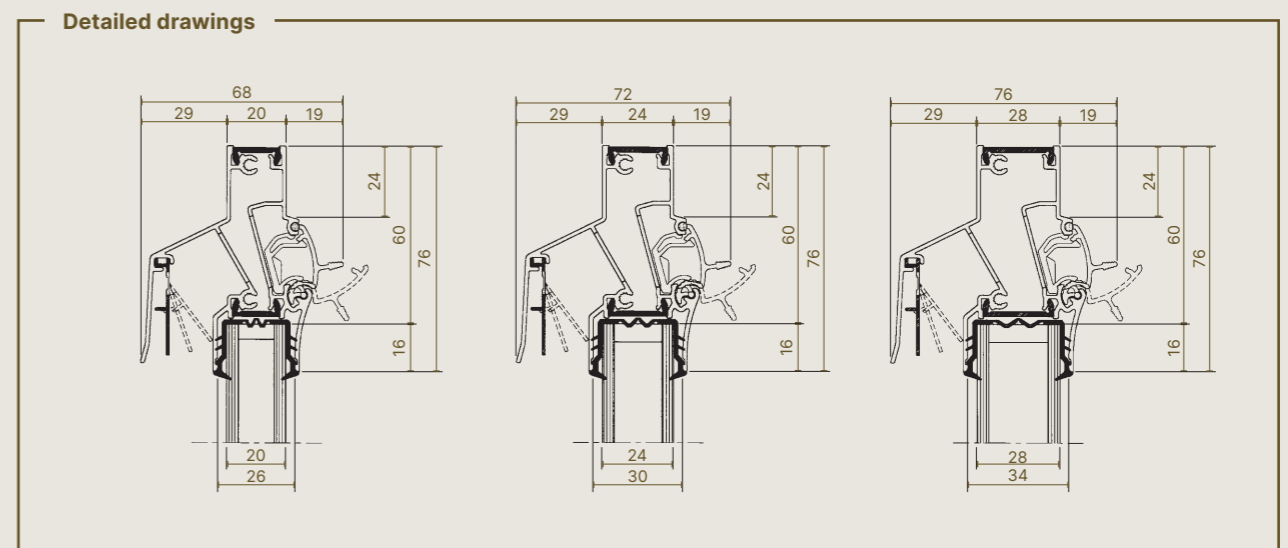

AR90

Self-regulating window vent

What sets the self-regulating AR90 apart is its flat inner profile which makes it the ideal solution for integration in the fixed part of a sliding window. On the outer profile AR90 comes with a water-resistant outer profile.

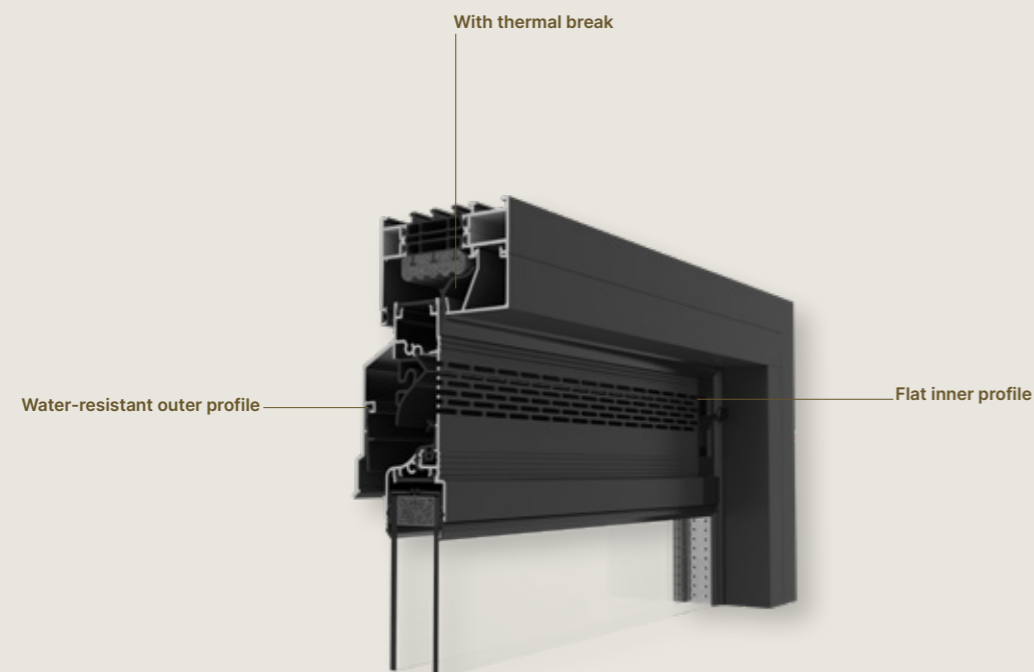

Technical details	
Airflow	
Equivalent area	14252 mm ² /m
Q at 1 Pa	11.2 l/s/m
Q at 1 Pa	40.3 m ³ /h/m
Q at 2 Pa	15.6 l/s/m
Q at 10 Pa	11.4 l/s/m
Q at 20 Pa	9.1 l/s/m
Sound reduction D_{n,e,w} (C;C_{tr})	
In open position	30 (-1;-2) dB
In closed position	45 (-1;-3) dB
Technical details	
Positions	5 positions
Controls	Cord, manual, motor, rod
U value	3.9 W/m ² K
Airflow at 50 Pa	<15% (in closed position)
Watertightness in closed position	Up to 650 Pa
Watertightness in open position	Up to 100 Pa
Dimensions	
Glass reduction	90 mm
Height	105 mm
Glass thickness	20, 24 or 28 mm
Max. length	2500 mm (2000 mm with motor control)



FLAP VENTILATORS
GLAZED-IN/AT TRANSOM

Technical properties	
Installation at transom	✓
With thermal break	✓
Self-regulating	Maximum supply of fresh air without draughts
Flat inner profile	✓
Insect-proof	✓

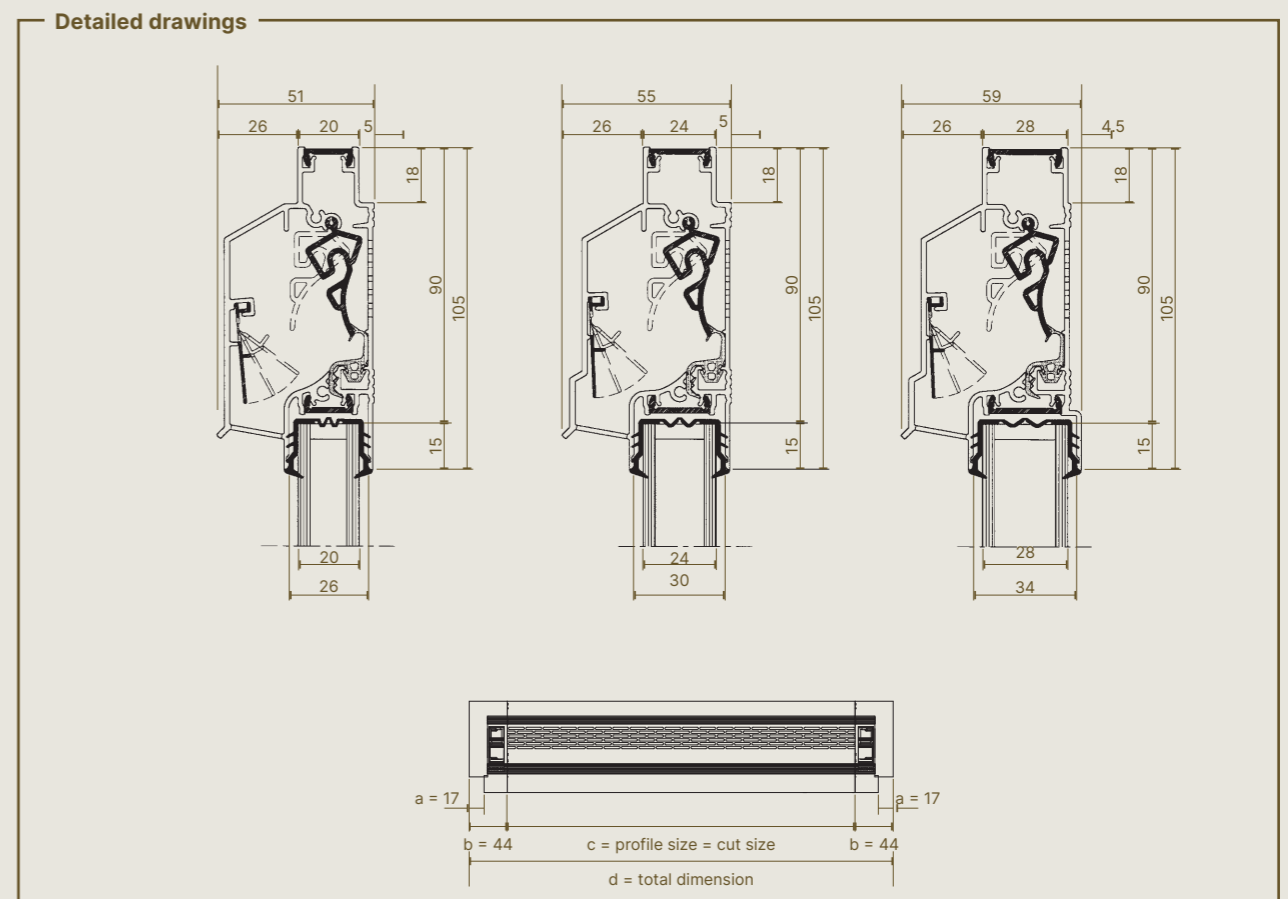

THM90^{EVO}

Flat, self-regulating window vent

THM90^{EVO} is a completely flat window vent, which makes it perfect for integration into sliding windows and doors. THM90^{EVO} can be placed either on the glass, at the bottom of the window (THM90PB^{EVO}) or between the profiles (THM90TR^{EVO}).

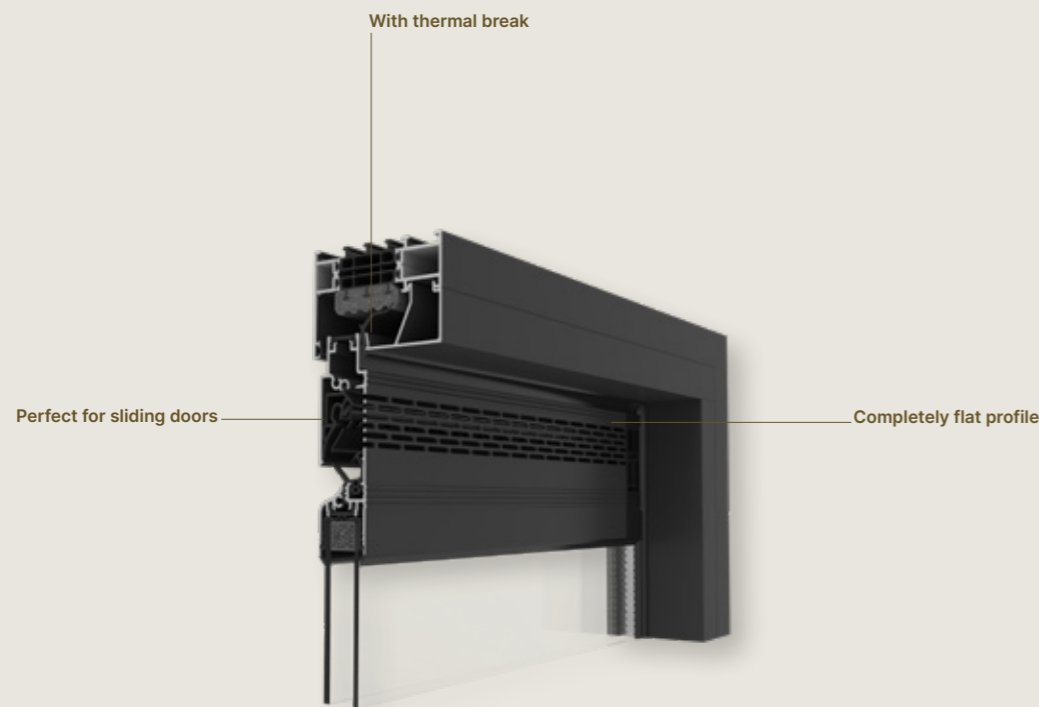

Technical details	
Airflow	
Equivalent area	14736 mm ² /m
Q at 1 Pa	11.6 l/s/m
Q at 1 Pa	41.7 m ³ /h/m
Q at 2 Pa	16.1 l/s/m
Q at 10 Pa	34.5 l/s/m
Q at 20 Pa	48.0 l/s/m
Sound reduction D_{n,e,w} (C;C_{tr})	
In open position	26 (0;0) dB
In closed position	45 (-1;-1) dB
Technical details	
Positions	5 positions
Controls	Cord, manual, motor, rod
U value	3.8 W/m ² K
Airflow at 50 Pa	<15% (in closed position)
Watertightness in closed position	Up to 650 Pa
Watertightness in open position	Up to 100 Pa
Dimensions	
Glass reduction	90 mm / 105* mm
Height	105 mm
Glass thickness	
THM90 ^{EVO}	20, 24, 28 or 33 mm
THM90PB ^{EVO}	20, 24 or 28 mm
THM90TR ^{EVO}	20 or 24 mm
Max. length	2500 mm (2000 mm with motor control)

* THM90TR^{EVO}

Detailed drawings

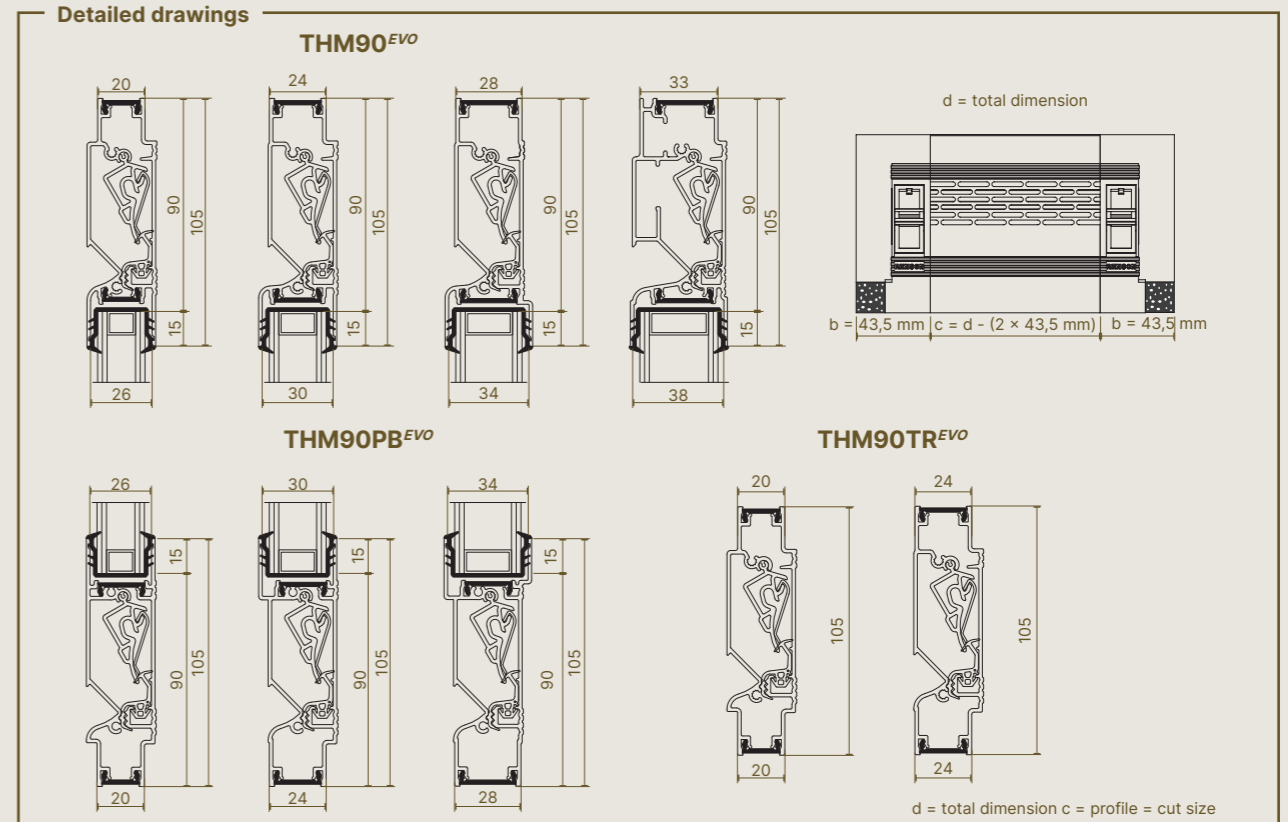

Technical properties	THM90 ^{EVO}	THM90PB ^{EVO}	THM90TR ^{EVO}
Installation	On the glass	At the bottom of the glass	Between profiles
Application	Ground floor		
With thermal break		✓	
Self-regulating	Maximum supply of fresh air without draughts		
Flat inner profile		✓	
Insect-proof		✓	

VARIAVENT®

Our self-regulating window vent, redesigned

Variavent is a self-regulating window vent with a contemporary look, owing to the sleek, straight lines of its exterior profile. As the successor to the well-known AR75, this new generation of window vent perfectly combines proven technologies and contemporary design.

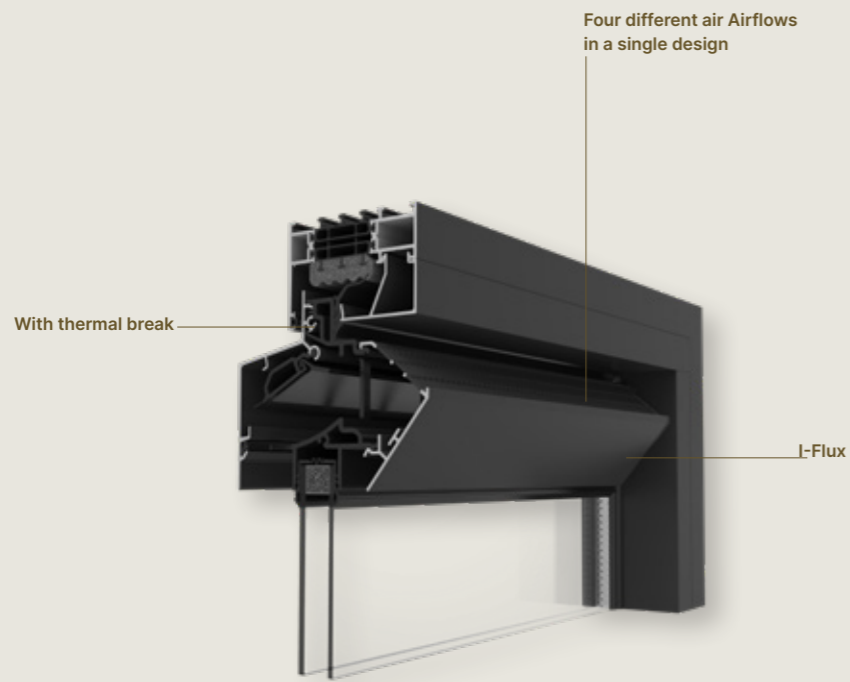

Technical details				
Airflow	Small	Medium	Large	XLarge
Equivalent area	12725 mm ² /m	19088 mm ² /m	22905 mm ² /m	26595 mm ² /m
Q at 1 Pa	10 l/s/m	15 l/s/m	18 l/s/m	20.9 l/s/m
Q at 1 Pa	36 m ³ /h/m	54 m ³ /h/m	64.8 m ³ /h/m	75.2 m ³ /h/m
Q at 2 Pa	14.2 l/s/m	21.4 l/s/m	25.6 l/s/m	28.5 l/s/m
Q at 10 Pa	12.7 l/s/m	19.1 l/s/m	22.9 l/s/m	25.4 l/s/m
Q at 20 Pa	13.6 l/s/m	20.4 l/s/m	24.4 l/s/m	27.1 l/s/m
Manual restriction with flow restrictor				
Sound reduction D _{n,e,w} (C;C _{tr})				
In open position	25 (-1;-1)			
In closed position	40 (-1;-2)			
Technical details				
Position control	Infinitely adjustable			
Controls	Cord, manual, rod			
U value	2.80 W/m ² K			
Airflow at 50 Pa	<15% (in closed position)			
Watertightness in closed position	Up to 650 Pa			
Watertightness in open position	Up to 50 Pa			
Dimensions				
Glass reduction	80 mm			
Height	97 mm			
Glass thickness	20, 24, 28, 32, 36, 40, 44* mm			
Max. length	3000 mm			

* not for installation at transom



Variavent® - Flat

Technical properties	
Installation at transom	✓
With thermal break	✓
Self-regulating	✓
I-Flux	Fresh air supply without draughts, manually adjustable
Filters (Optional)	Pollux filter type 02
Flat inner profile	✓ (Variavent Flat)
Insect-proof	✓

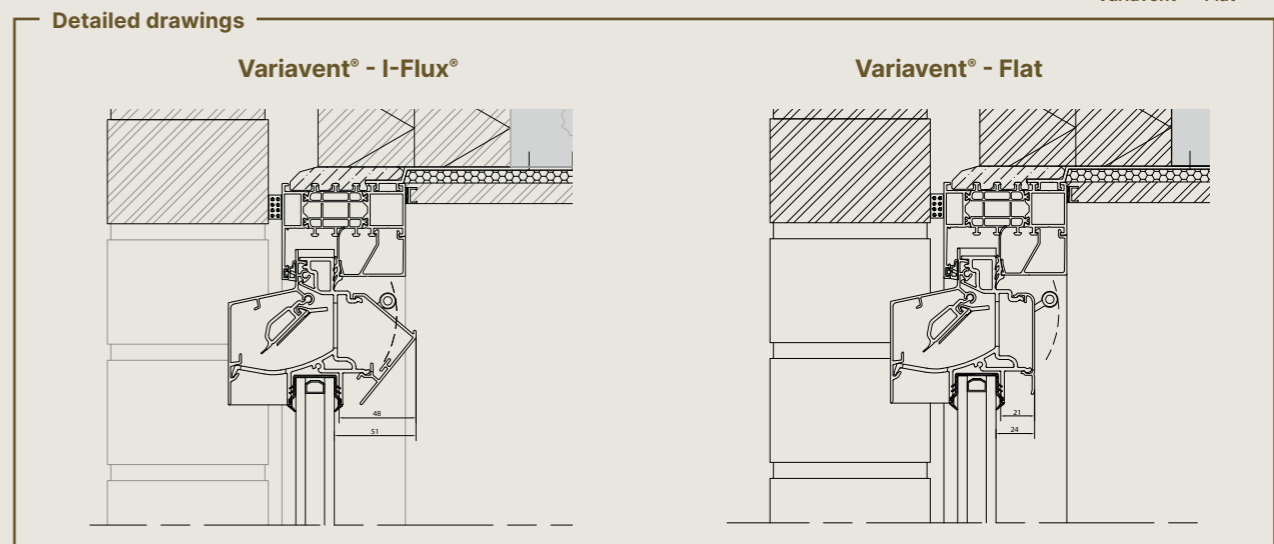

SONOVENT®

The self-regulating window vent with superior sound reduction

Sonovent is a versatile vent that offers extremely high physical comfort (= fresh, healthy air without draughts) and high acoustic comfort (= sound reduction up to 48 dB). Five different types of Sonovent are available: XSmall, Small, Medium, Large and XLarge, each with four different airflow openings (10, 15, 20 or 25 mm). The result is a total of 20 possible alternatives. What's more: the thermal breaks can be placed in different positions, depending on the model and installation method. As such, Sonovent offers the perfect solution for every situation.

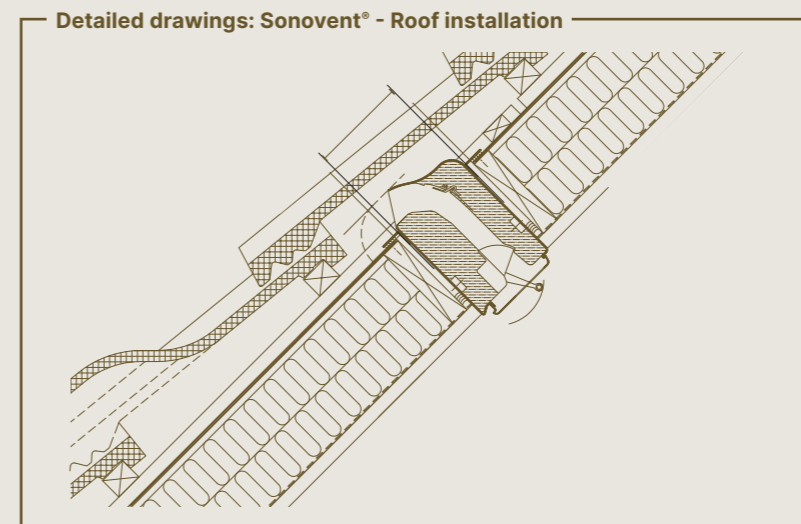
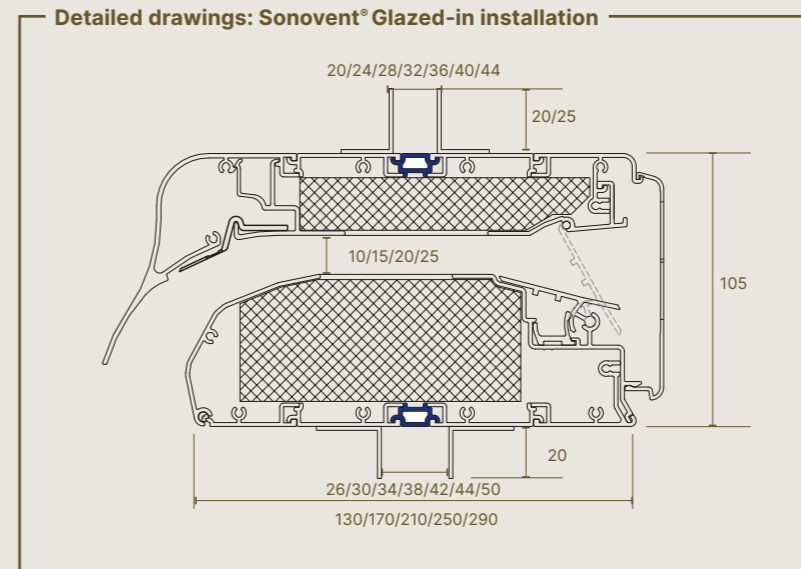
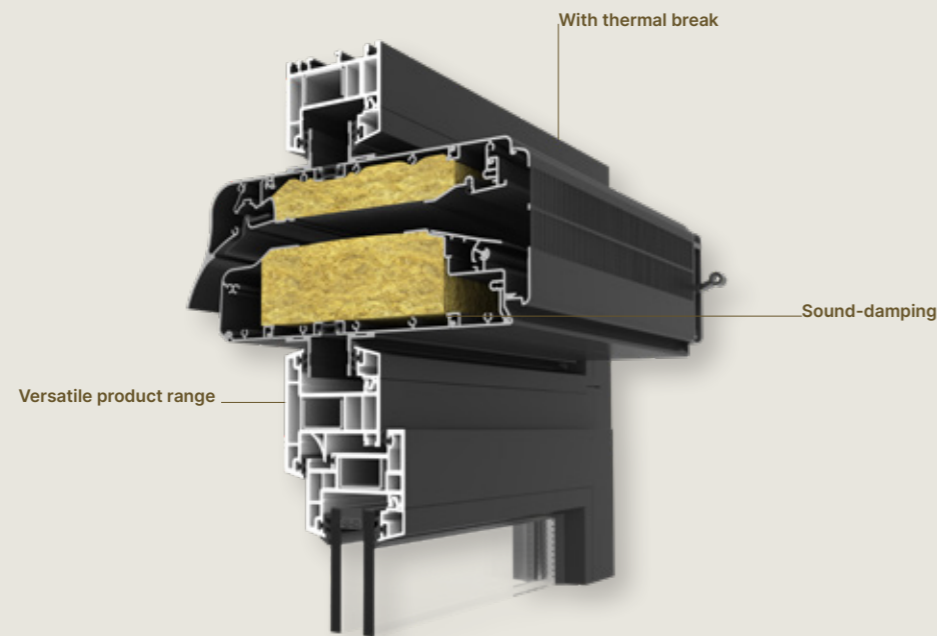

Installation

Sonovent has been developed for installation on the glass or at transom position (recommended). Hidden installation behind blades or in the ventilated panel of a curtain wall system is also possible and is generally applicable in office buildings, schools, hospitals and so on.

By choosing the right Sonovent model for your application and by allowing for various lengths, you can realise both the required air Airflow and the necessary acoustic performance.

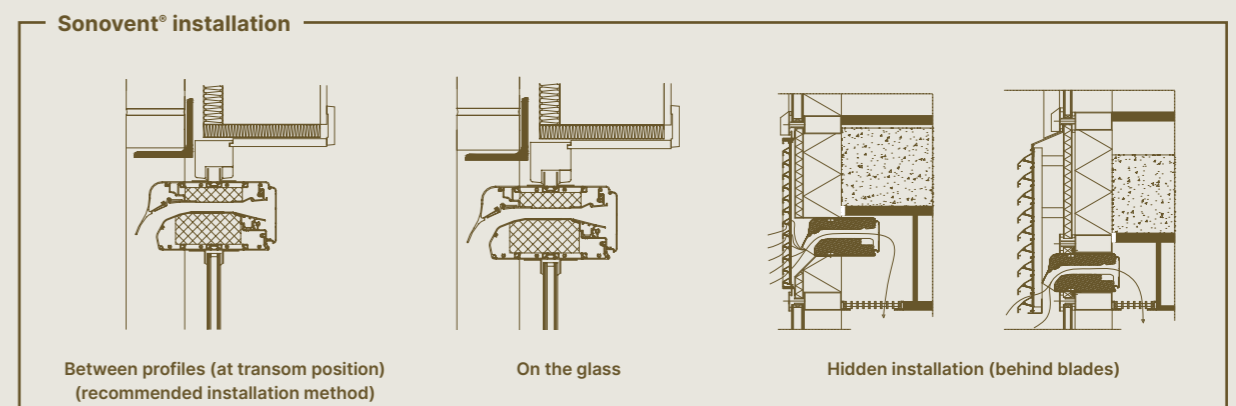

We recommend against installing Sonovent on the tilt and turn section of a window.

Technical properties	
Installation at transom	✓
Sloped installation	Minimum gradient: 22.5°
With thermal break	✓
Self-regulating	Maximum supply of fresh air without draughts
Flat inner profile	✓
Sound-damping	Variable Sound reduction depending on the model selected
Insect-proof	✓

The versatile Sonovent® range

Five different models with varying thermal break positions

- Models: XSmall - Small - Medium - Large - XLarge (XXLarge upon request)
- Thermal break: different positions, 1 to 6

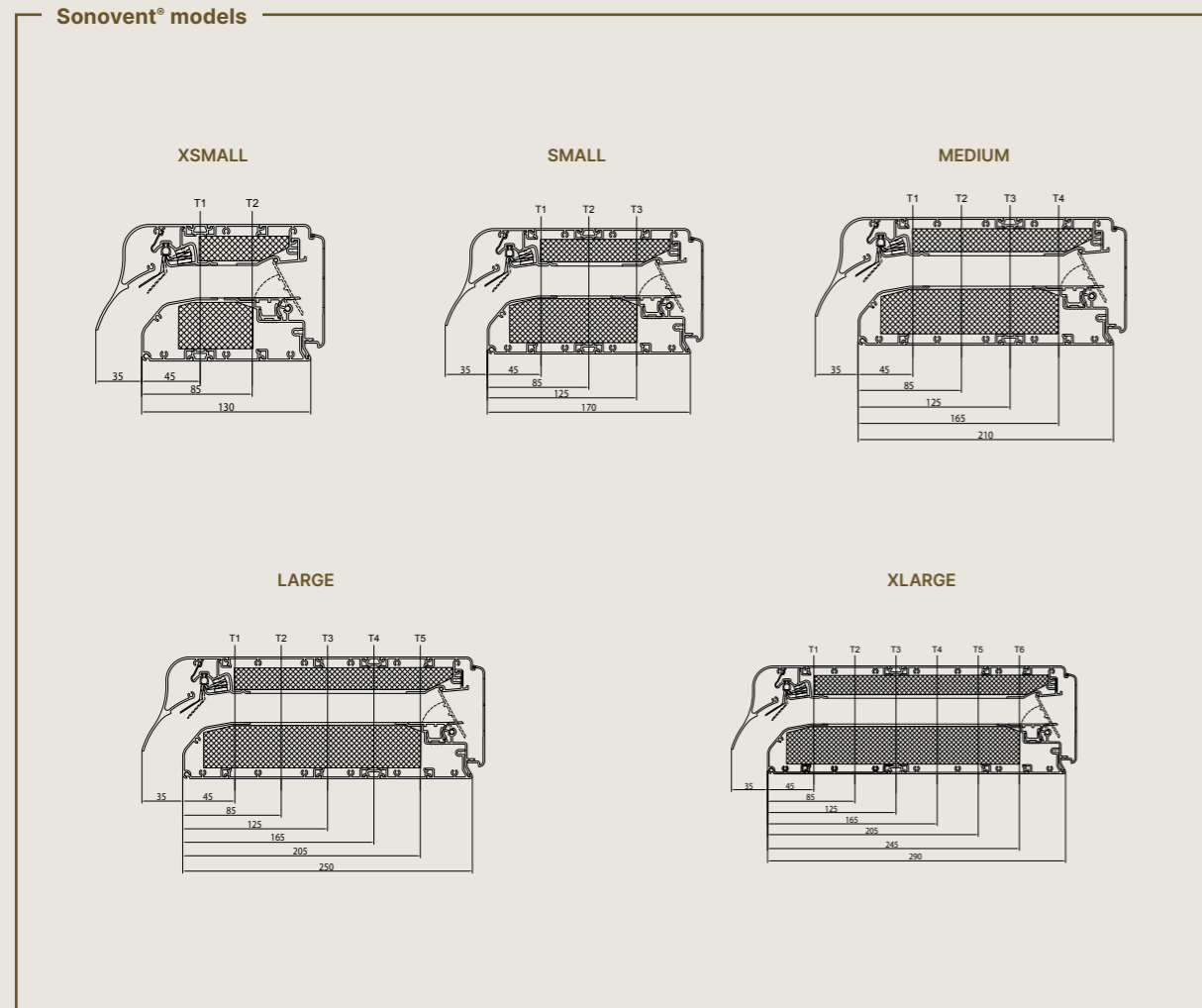

Possible thermal break positions	XSmall	Small	Medium	Large	XLarge
On the glass	1 - 2	1 - 2 - 3	1* - 2 - 3 - 4*	1* - 2 - 3 - 4 - 5*	1* - 2* - 3 - 4 - 5* - 6*
At transom position	1 - 2	1 - 2 - 3	1 - 2 - 3 - 4	1* - 2 - 3 - 4 - 5*	1* - 2* - 3 - 4 - 5* - 6*
Hidden installation	1 - 2	1 - 2 - 3	1 - 2 - 3 - 4	1* - 2 - 3 - 4 - 5*	1* - 2* - 3 - 4 - 5* - 6*

* Upon request

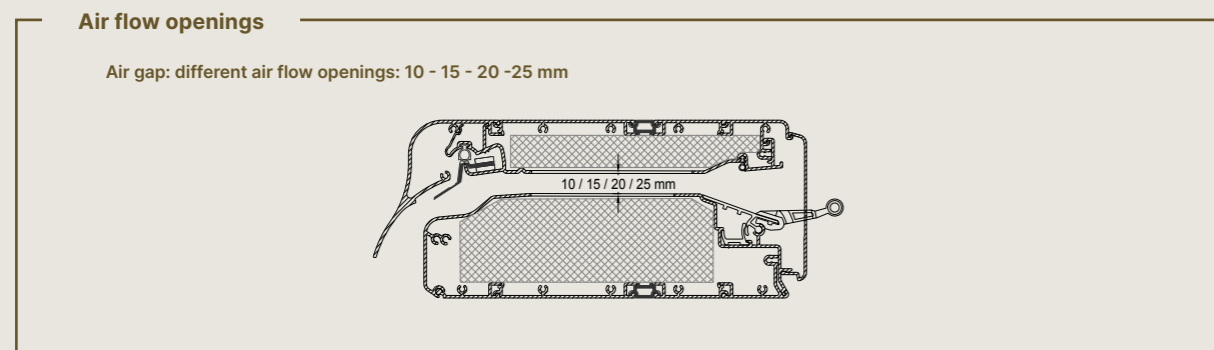

Technical details						
Airflow		XSmall	Small	Medium	Large	XLarge
Equivalent area	10 mm airflow opening	18416 mm ² /m	18324 mm ² /m	18070 mm ² /m	16670 mm ² /m	14888 mm ² /m
	15 mm airflow opening	30693 mm ² /m	30540 mm ² /m	27359 mm ² /m	26341 mm ² /m	22269 mm ² /m
	20 mm airflow opening	32995 mm ² /m	32831 mm ² /m	34258 mm ² /m	33085 mm ² /m	32067 mm ² /m
	25 mm airflow opening	35041 mm ² /m	34867 mm ² /m	35121 mm ² /m	34485 mm ² /m	33721 mm ² /m
Q at 1 Pa	10 mm airflow opening	14,5 l/s/m	14,4 l/s/m	14,2 l/s/m	13,1 l/s/m	11,7 l/s/m
	15 mm airflow opening	24,1 l/s/m	25,8 l/s/m	21,5 l/s/m	20,7 l/s/m	17,5 l/s/m
	20 mm airflow opening	25,9 l/s/m	27,4 l/s/m	27,0 l/s/m	26,0 l/s/m	25,2 l/s/m
	25 mm airflow opening	27,5 l/s/m	26,6 l/s/m	27,6 l/s/m	27,1 l/s/m	26,5 l/s/m
Q at 1 Pa	10 mm airflow opening	52,1 m ³ /h/m	51,8 m ³ /h/m	51,1 m ³ /h/m	47,2 m ³ /h/m	42,1 m ³ /h/m
	15 mm airflow opening	86,8 m ³ /h/m	86,4 m ³ /h/m	77,4 m ³ /h/m	74,5 m ³ /h/m	63,0 m ³ /h/m
	20 mm airflow opening	93,3 m ³ /h/m	92,9 m ³ /h/m	97,2 m ³ /h/m	93,6 m ³ /h/m	90,7 m ³ /h/m
	25 mm airflow opening	99,1 m ³ /h/m	98,6 m ³ /h/m	99,4 m ³ /h/m	97,6 m ³ /h/m	95,4 m ³ /h/m
Q at 2 Pa	10 mm airflow opening	20,4 l/s/m	20,6 l/s/m	20,7 l/s/m	18,8 l/s/m	16,8 l/s/m
	15 mm airflow opening	34,1 l/s/m	33,9 l/s/m	30,8 l/s/m	29,5 l/s/m	24,7 l/s/m
	20 mm airflow opening	36,9 l/s/m	36,7 l/s/m	38,2 l/s/m	37,0 l/s/m	35,7 l/s/m
	25 mm airflow opening	39,2 l/s/m	39,0 l/s/m	39,4 l/s/m	38,6 l/s/m	37,8 l/s/m
Q at 2 Pa	10 mm airflow opening	74,5 m ³ /h/m	74,2 m ³ /h/m	74,5 m ³ /h/m	67,7 m ³ /h/m	60,5 m ³ /h/m
	15 mm airflow opening	122,7 m ³ /h/m	122,0 m ³ /h/m	110,9 m ³ /h/m	106,2 m ³ /h/m	88,9 m ³ /h/m
	20 mm airflow opening	132,8 m ³ /h/m	132,1 m ³ /h/m	137,5 m ³ /h/m	133,2 m ³ /h/m	128,5 m ³ /h/m
	25 mm airflow opening	141,1 m ³ /h/m	140,4 m ³ /h/m	141,8 m ³ /h/m	139,0 m ³ /h/m	136,1 m ³ /h/m
Q at 10 Pa	10 mm airflow opening	19,1 l/s/m	19,1 l/s/m	18,1 l/s/m	16,4 l/s/m	14,7 l/s/m
	15 mm airflow opening	30,4 l/s/m	30,4 l/s/m	26,9 l/s/m	25,7 l/s/m	21,5 l/s/m
	20 mm airflow opening	29,5 l/s/m	29,5 l/s/m	33,3 l/s/m	32,3 l/s/m	31,1 l/s/m
	25 mm airflow opening	29,9 l/s/m	29,9 l/s/m	32,8 l/s/m	29,6 l/s/m	33,0
Q at 20 Pa	10 mm airflow opening	23,6 l/s/m	23,6 l/s/m	14,7 l/s/m	13,4 l/s/m	12,0 l/s/m
	15 mm airflow opening	29,4 l/s/m	29,4 l/s/m	21,9 l/s/m	21,0 l/s/m	17,6 l/s/m
	20 mm airflow opening	30,1 l/s/m	30,1 l/s/m	27,2 l/s/m	26,4 l/s/m	25,4 l/s/m
	25 mm airflow opening	28,0 l/s/m	28,0 l/s/m	27,5 l/s/m	25,8 l/s/m	26,9 l/s/m

Sound reduction $D_{n,w}$ ($C; C_w$) in open position						
10 mm airflow opening	36 (-1;-1) dB	41 (-1;-2) dB	44 (-1;-4) dB	46 (-1;-4) dB	48 (-1;-3) dB	
15 mm airflow opening	31 (0;0) dB	36 (0;-1) dB	41 (0;-3) dB	45 (-1;-4) dB	47 (-1;-5) dB	
20 mm airflow opening	32 (-1;-1) dB	35 (0;-1) dB	39 (-1;-3) dB	41 (-1;-3) dB	43 (-1;-4) dB	
25 mm airflow opening	31 (-1;-1) dB	34 (0;-2) dB	37 (0;-3) dB	40 (-1;-4) dB	41 (-1;-4) dB	

Sound reduction $D_{n,w}$ ($C; C_w$) in closed position: n/a

Technical details	
Positions	Infinitely adjustable
Controls	Cord, manual, motor, rod
U value	2,8 W/m ² K
Airflow at 50 Pa	<15% (in closed position)
Windproofness (EN1026)	up to 650 Pa
Watertightness in closed position	Up to 1200 Pa

Dimensions	
Glass reduction	130 mm (20 mm flange), 135 mm (25 mm flange)
Height	105 mm (total height with flange profiles: 145 or 150 mm)
Glass thickness	20, 24, 28, 32, 36, 40, 44 mm (other glass thicknesses upon request)
Glazing channels	26, 30, 34, 38, 42, 46, 50 mm (other glazing channels upon request)
Max. length	2000 mm (installation on the glass) / 2500 mm (installation at transom)
Depth/Total depth	130 mm (XS) 170 mm (S), 210 mm (M), 250 mm (L) or 290 mm (XL)

Sonovent® roof installation dimensions					
Height	105 mm (ventilation box height) / 155 mm (total height with flange profiles)				
Roof shell thickness	130 mm	170 mm	210 mm	250 mm	290 mm
Minimum inclination angle	22.5°				
Roof opening	115 mm				
Maximum length	1250 mm				

SONOVENT® COMPACT

GLAZED IN/
AT TRANSOM
POSITION

Compact self-regulating acoustic window vent

Sonovent Compact is Sonovent's little brother. This compact, sound-damping window vent offers a great balance between acoustic damping and airflow.

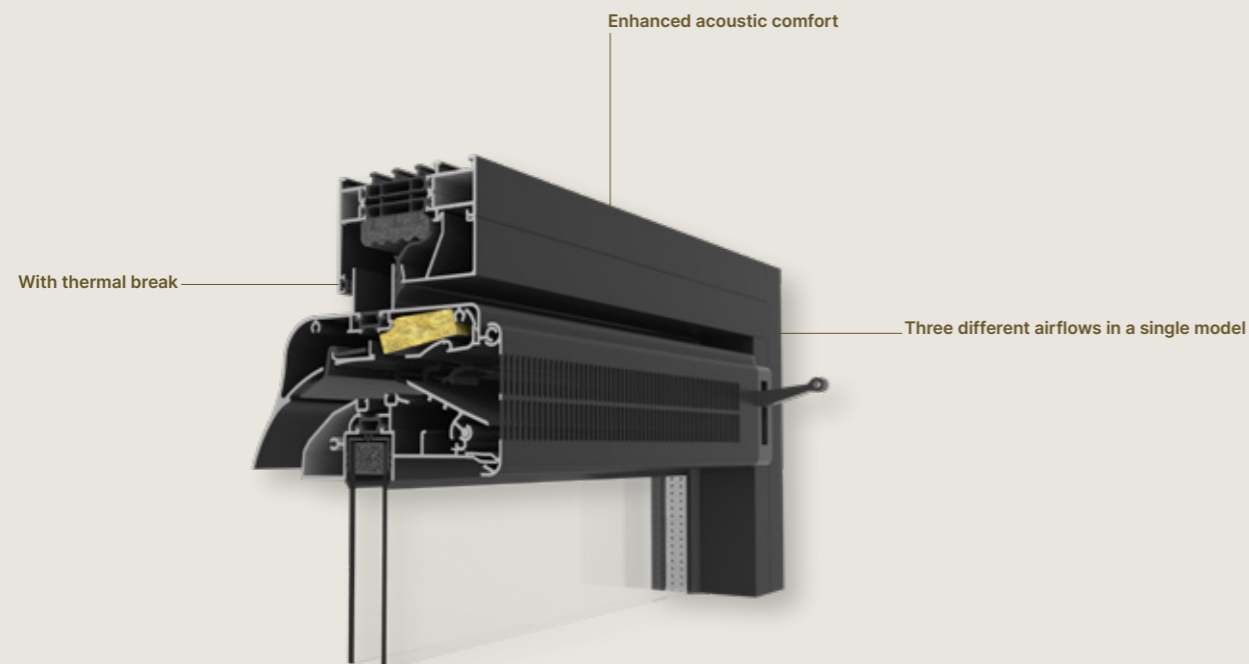

Technical properties	
Installation at transom	✓
With thermal break	✓
Self-regulating	Maximum supply of fresh air without draughts
Sound-damping	Variable Sound reduction depending on the airflow opening selected
Flat inner profile	✓
Insect-proof	✓

Technical details		
Airflow		
Equivalent area	10 mm airflow opening	15334 mm ² /m
	13 mm airflow opening	19278 mm ² /m
	15 mm airflow opening	24687 mm ² /m
Q at 1 Pa	10 mm airflow opening	12,1 l/s/m
	13 mm airflow opening	15,2 l/s/m
	15 mm airflow opening	19,4 l/s/m
Q at 1 Pa	10 mm airflow opening	43,4 m ³ /h/m
	13 mm airflow opening	54,5 m ³ /h/m
	15 mm airflow opening	69,8 m ³ /h/m
Q at 2 Pa	10 mm airflow opening	16,4 l/s/m
	13 mm airflow opening	18,8 l/s/m
	15 mm airflow opening	19,9 l/s/m
Q at 2 Pa	10 mm airflow opening	58,9 m ³ /h/m
	13 mm airflow opening	67,7 m ³ /h/m
	15 mm airflow opening	71,5 m ³ /h/m
Q at 10 Pa	10 mm airflow opening	17,3 l/s/m
	13 mm airflow opening	18,8 l/s/m
	15 mm airflow opening	18,6 l/s/m
Q at 20 Pa	10 mm airflow opening	17,8 l/s/m
	13 mm airflow opening	18,7 l/s/m
	15 mm airflow opening	19,1 l/s/m

Sound reduction D _{n,e,w} (C;C _{tr})	
In open position	
10 mm airflow opening	36 (0;-1) dB
13 mm airflow opening	35 (0;-1) dB
15 mm airflow opening	33 (0;-1) dB
In closed position	
N/a	

Technical details	
Positions	Infinitely adjustable
Controls	Cord, manual, rod
U value	3.45 W/m ² K
Airflow at 50 Pa	<15% (in closed position)
Watertightness in closed position	Up to 650 Pa

Dimensions	
Glass reduction	78 mm
Height	75 mm (ventilation box height) / 95 mm (total height with flange profiles)
Glass thickness	20, 24, 28, 32 or 36 mm
Max. length	2000 mm (installation on the glass) or 2500 mm (Installation at transom)

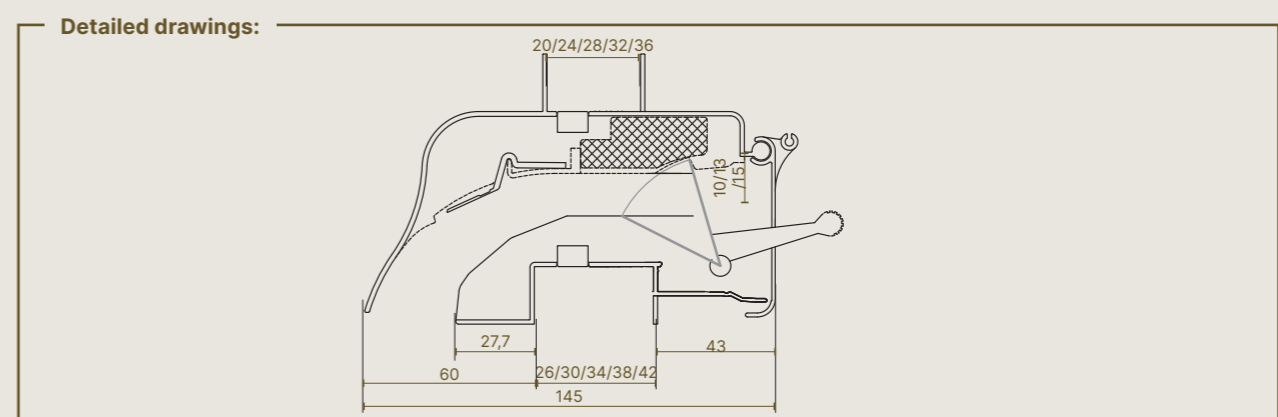

FLAP VENTILATORS
GLAZED-IN/AT TRANSOM



ROLLER SHUTTER FLAP VENTILATOR

Transivent is a self-regulating window vent with a thermal break designed especially for installation in a roller shutter box. This product has been developed for situation where ventilation may be somewhat of an afterthought, but is still required nonetheless. Thanks to its integration in the roller shutter box, Transivent can be used to ventilate various rooms around your home in a simple way.



ROLLER SHUTTER
FLAP VENTILATOR

TRANSIVENT®

Self-regulating window vents for roller shutter boxes

The curved aluminium inner profile directs the air flow upwards.

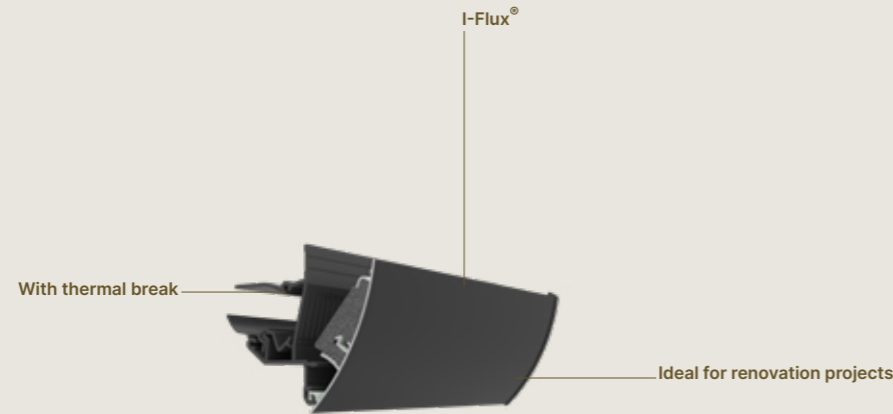

Technical details	
Airflow	
Equivalent area	13748 mm ² /m
Q at 1 Pa	10.8 l/s/m
Q at 1 Pa	38.9 m ³ /h/m
Q at 2 Pa	15.2 l/s/m
Q at 10 Pa	20.1 l/s/m
Q at 20 Pa	19.9 l/s/m
Sound reduction D_{n,e,w} (C;C_{tr})	
In open position	28 (-1;-2) dB
In closed position	44 (-1;-2) dB
Technical details	
Positions	5 positions
Controls	Cord, manual or rod
U value	3.0 W/m ² K
Airflow at 50 Pa	<15% (in closed position)
Watertightness in closed position	Up to 650 Pa
Watertightness in open position	Up to 150 Pa
Dimensions	
Height	91 mm
Installation height	48 mm
Slot height	50 mm
Recessed depth	60 mm
Max. length	2200 mm (1500 mm with cord control)

Technical properties	
With thermal break	✓
Self-regulating	✓
I-Flux	Fresh air supply without draughts, manually adjustable
Insect-proof	✓

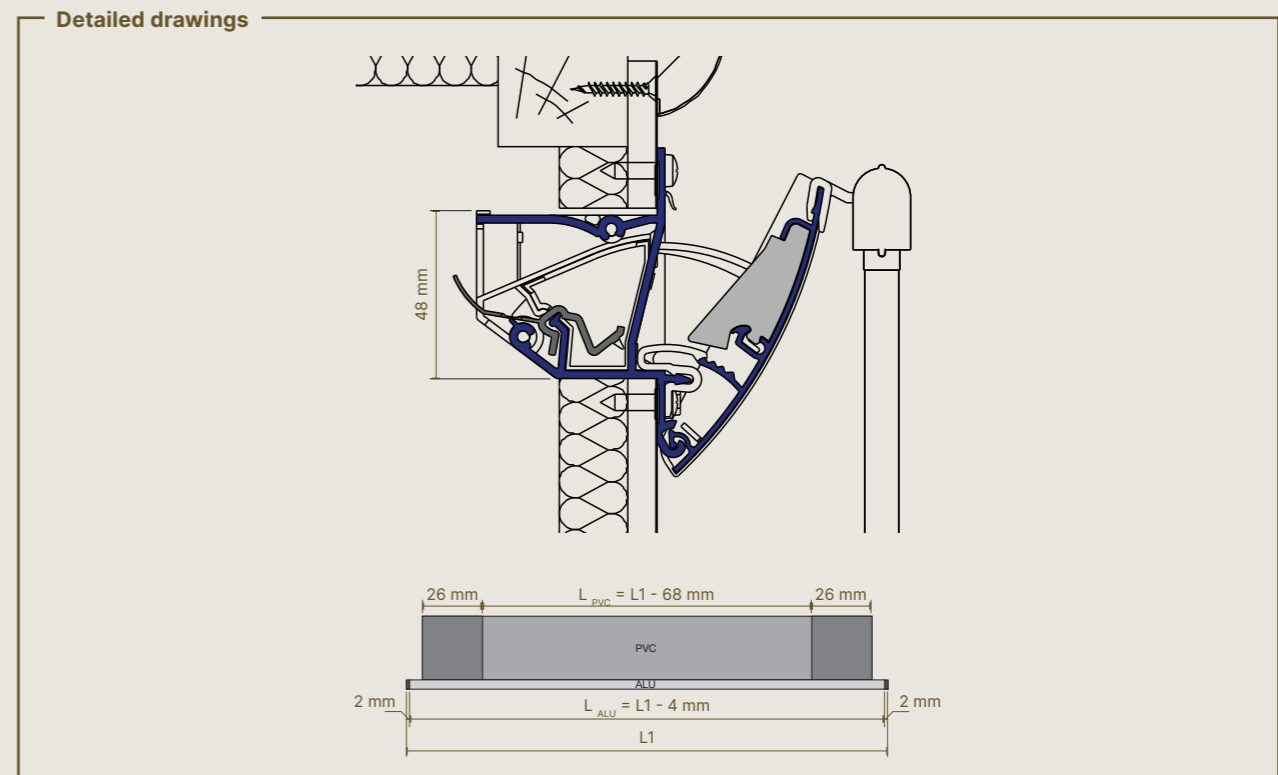

ROLLER SHUTTER FLAP VENTILATOR



SLIDING VENTS

Sliding vents offer a simple way to control the circulation of air, allowing you to enjoy a constant supply of fresh air from outside.



SLIDING VENTS

THL100(V)



Sliding ventilation

THL100 is a made-to-measure sliding ventilation system with a thermal break and blades that can be installed vertically (THL100V) or horizontally (THL100). THL100V delivers a natural circulation of air: fresh air comes in below, and humid and warm air is extracted above.

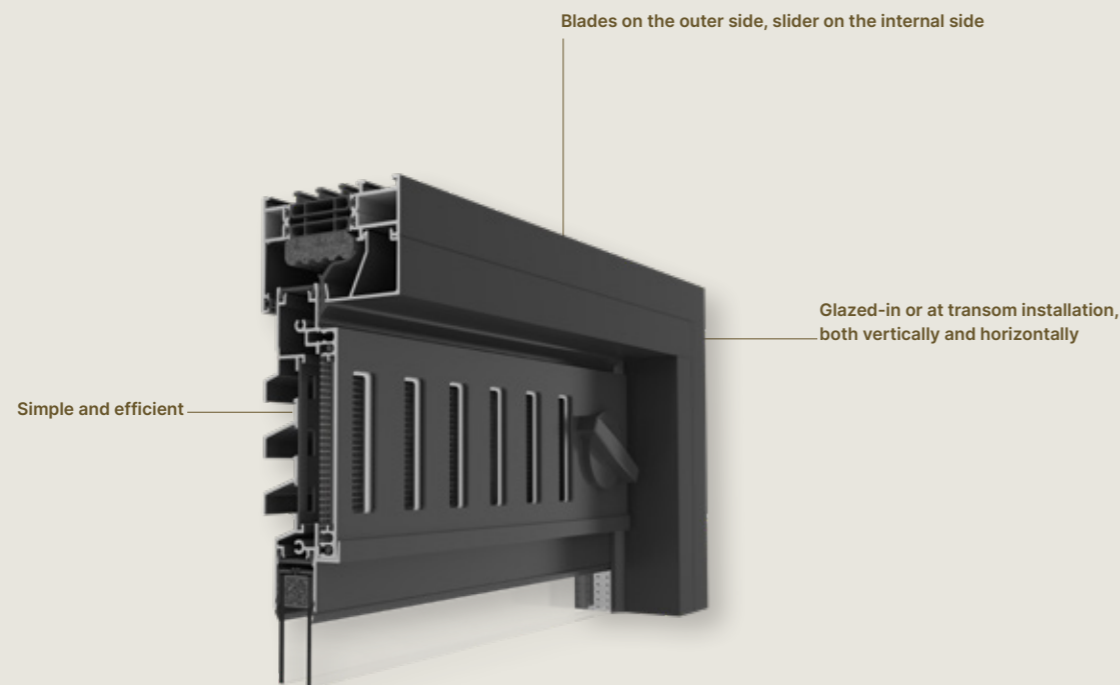

Technical details		
Airflow	THL100	THL100V
Equivalent area	16759 mm ² /m	12770 mm ² /m
Q at 1 Pa	13.2 l/s/m	10.0 l/s/m
Q at 1 Pa	47.4 m ³ /h/m	36.1 m ³ /h/m
Q at 2 Pa	18.7 l/s/m	14.2 l/s/m
Q at 10 Pa	41.6 l/s/m	32.1 l/s/m
Q at 20 Pa	58.9 l/s/m	45.5 l/s/m
Sound reduction $D_{n,e,w}$ (C;C _{tr})		
In open position	22 (0;0) dB	
In closed position	42 (-1;-2) dB	
Technical details		
Positions	Infinitely adjustable	
Controls	Chain, cord, motor, manually or rod	
U value	3.9 W/m ² K	
Airflow at 50 Pa	n/a	
Watertightness in closed position	Up to 400 Pa	n/a
Watertightness in open position	n/a	
Dimensions		
Glass reduction	129 mm	
Height	144 mm	
Glass thickness	20, 24 or 28 mm	
Max. length	3500 mm	

Technical properties	THL100 / THL100V	THL100-TR / THL100V-TR
Installation	Glazed-in	At transom
With thermal break		✓
Self-regulating		-
Insect-proof		✓

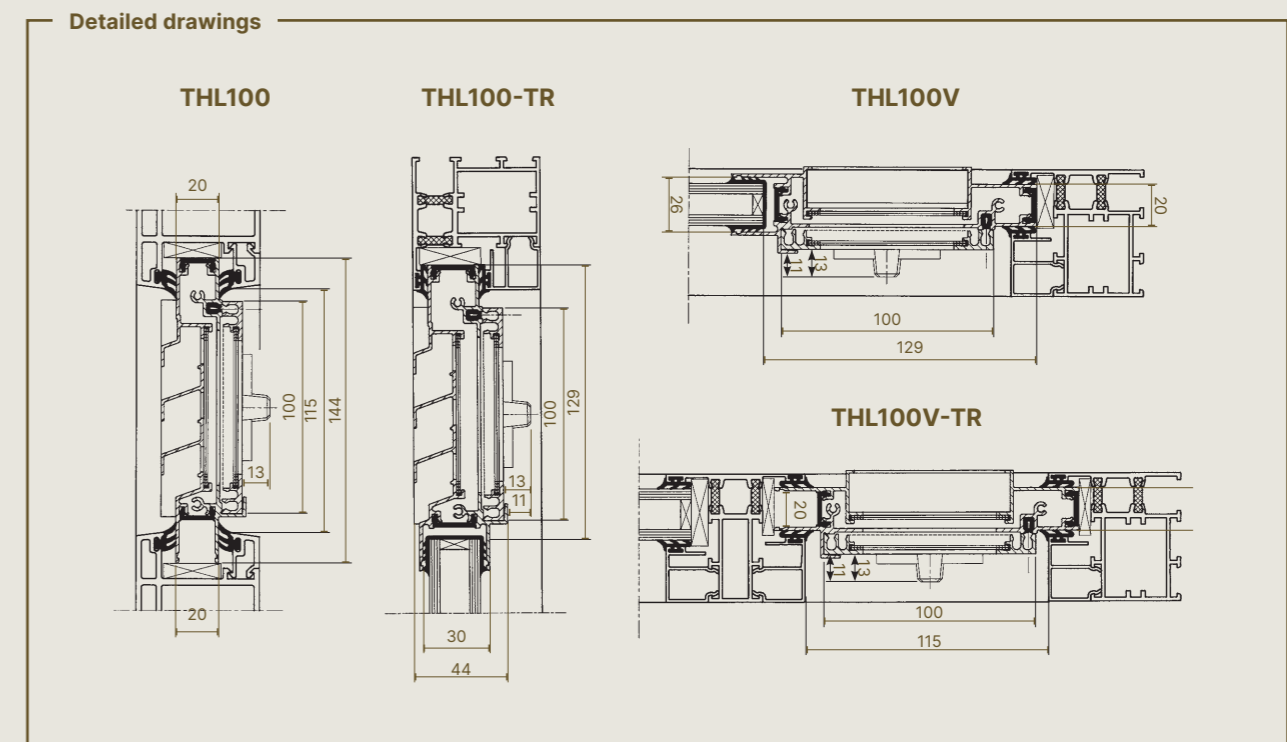

T100 - T130 - T150



Horizontal sliding ventilation for at transom installation

T100, T130 and T150 are aluminium sliding ventilation systems without a thermal break, designed for at transom installation. As a standard, these vents consist of two separate parts. The outer part is a decorative vent with angled blades to prevent water from seeping in. The inner part contains a manually controllable slider to control the incoming airflow.

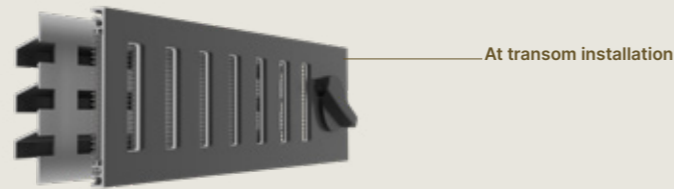

Technical properties	
Installation	Suitable for at transom installation
With thermal break	-
Self-regulating	-
Insect-proof	✓

Note: Not suitable for installation in the direct vicinity of seawater and the beach

Technical details			
Airflow	T100	T130	T150
Equivalent area	17326 mm ² /m	24589 mm ² /m	27992 mm ² /m
Q at 1 Pa	13,6 l/s/m	19,3 l/s/m	22,0 l/s/m
Q at 1 Pa	49,0 m ³ /h/m	69,6 m ³ /h/m	79,2 m ³ /h/m
Q at 2 Pa	19,5 l/s/m	27,7 l/s/m	31,9 l/s/m
Q at 10 Pa	43,8 l/s/m	62,1 l/s/m	71,5 l/s/m
Q at 20 Pa	61,9 l/s/m	87,9 l/s/m	101,0 l/s/m
Sound reduction D _{n,e,w} (C;C _{tr})			
In open position	n/a		
In closed position	n/a		
Technical details			
Positions	Infinitely adjustable		
Controls	Chain, cord, manually, motor or rod		
U value	n/a		
Airflow at 50 Pa	n/a		
Watertightness in closed position	n/a		
Watertightness in open position	n/a		
Dimensions			
Height	100 mm	130 mm	150 mm
Max. length	3500 mm		

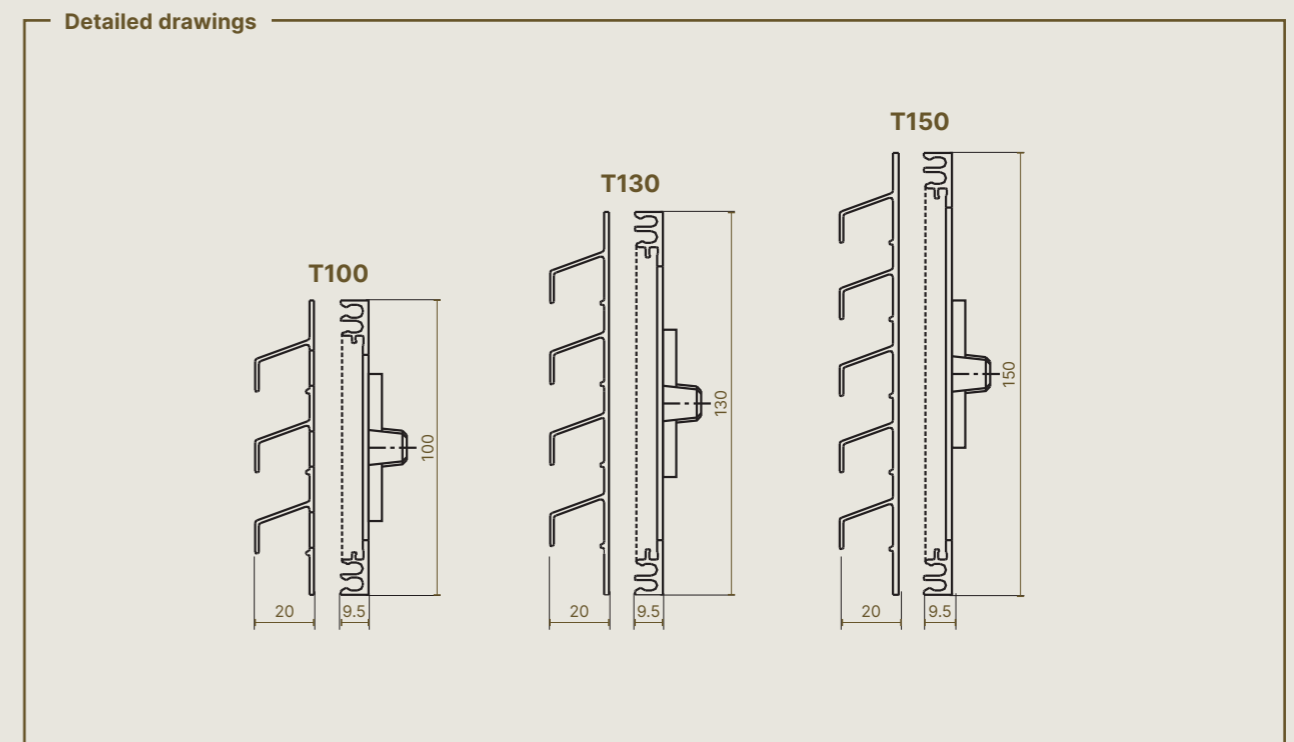



SLOTVENTS

Renson has developed an extensive range of slotvents. The Renson slotvents are manufactured in aluminium, this to ensure the highest possible quality and durability. These aluminium slotvents can be powdercoated in any color making a perfect integration possible on wooden, PVC and aluminium window frames. Renson proposes some standard lengths for the slotvents but most of the types can be made to measure.

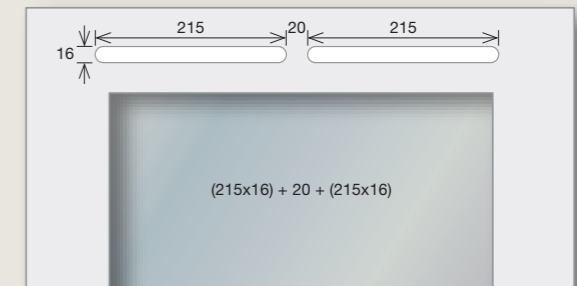
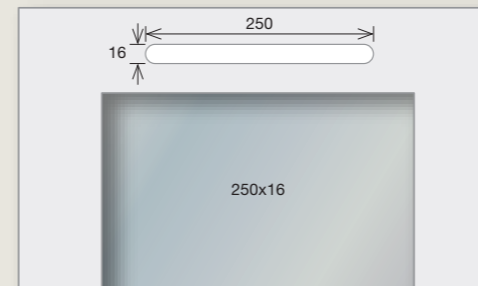

SONOSLOT®



Self-regulating acoustic slotvent kit

The Sonoslot is a self-regulating, sound absorbing slotvent kit consisting of an external slotvent, internal slotvent and a plastic sleeve with integrated sound absorbing baffle in-between. This slotvent is suitable for all window depths and can be used for window frames made of wood, PVC and aluminium. Optionally, the Sonoslot can also be installed in permanently open position, by clicking a special clip in the interior slotvent.

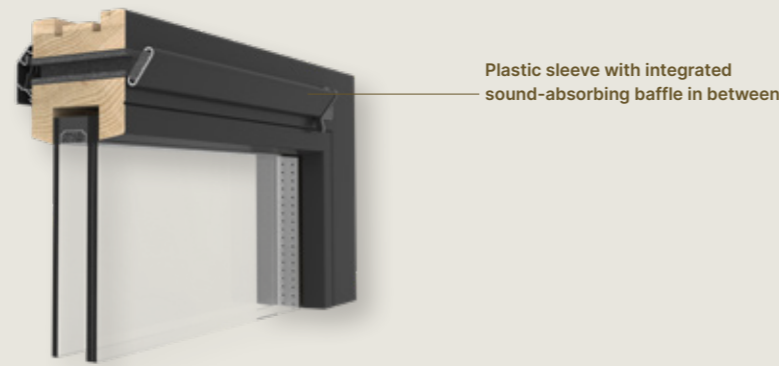

Technical characteristics				
Airflow	Sonoslot® 275 mm	Sonoslot® 375 mm	Sonoslot® 475 mm	Sonoslot® 700 mm
Equivalent area	1273 mm ²	1607 mm ²	2121 mm ²	3181 mm ²
Q at 1 Pa	1,0 l/s	1,3 l/s	1,7 l/s	2,5 l/s
Q at 1 Pa	3,6 m ³ /h	4,5 m ³ /h	6,0 m ³ /h	9,0 m ³ /h
Q at 2 Pa	1,4 l/s	1,7 l/s	2,3 l/s	3,4 l/s
Q at 10 Pa	3,2 l/s	4,0 l/s	5,3 l/s	8,0 l/s
Q at 20 Pa	3,3 l/s	4,2 l/s	5,6 l/s	8,4 l/s
Comfort				
Sound reduction Dn,e,w (C;Ctr)				
In open position	38 (0;0) dB	37 (0;0) dB	36 (0;0) dB	34 (0;0) dB
In closed position	-			
Technical characteristics				
Controllable internal flap	Continuous adjustment			
Control options internal flap	Manual			
U value	1,4 W/m ² .K			
Air leakage at 50 Pa	< 15 % in closed position			
Watertightness in closed position, up to	-			
Watertightness in open position, up to	-			
Dimensions				
Height	35 mm			
Length	275 mm	375 mm	475 mm	700 mm
Slotsize opening	(105,5 × 16) + 24 + (105,5 × 16)	(105,5 × 16) + 14,3 + (105,5 × 16) + 14,3 + (105,5 × 16)	(105,5 × 16) + 7,5 + (105,5 × 16) + 7,5 + (105,5 × 16) + 7,5 + (105,5 × 16)	(105,5 × 16) + 7,5 + (105,5 × 16) + 7,5 + (105,5 × 16) + 7,5 + (105,5 × 16) + 7,5 + (105,5 × 16)
Length acoustic foam	2 × 103 mm	3 × 103 mm	4 × 103 mm	6 × 103 mm
Depth acoustic foam	70 mm			
Depth plastic sleeve	90 mm			

Technical properties	
Installation	Through the window frame
Sound absorbing	38 (0;0) dB in open position
i-Flux®	✓
Insect-proof	✓

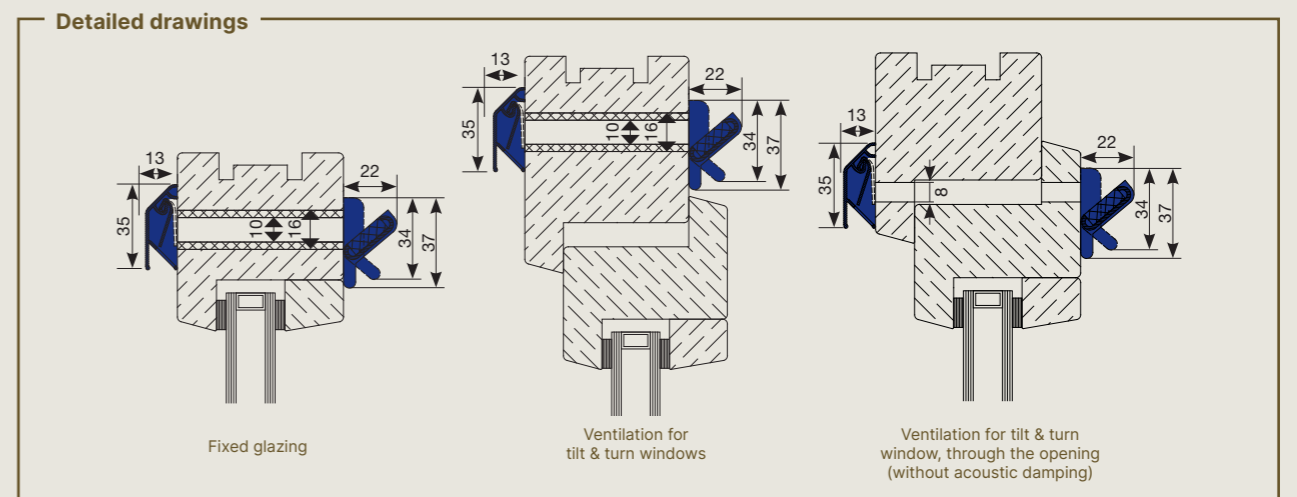

SONOSLOT® MAX



Self-regulating slotvent kit with high acoustic damping

Sonoslot Max is a self-regulating slotvent kit offering a higher sound absorption than the Sonoslot, existing of an external slotvent, an internal slotvent and a plastic sleeve with integrated sound absorbing baffle in-between. The aluminium external slotvent is self-regulating, which keeps the airflow fairly uniform in strong winds and prevents draughts. Moreover, the external slotvent is perforated and also acts as an insect mesh screen. The internal slotvent of the Sonoslot Max is permanently open and includes extra acoustic damping. The noise-damping baffle is standard 70 mm thick and the plastic sleeve is standard 90 mm thick, but both can easily be adapted to suit different window frame depths. This slotvent combination suits for all window depths. It can be used for both new build and renovation projects.

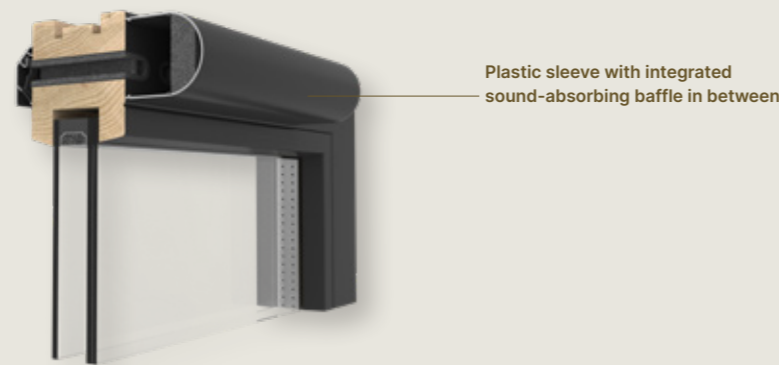

Technical properties	
Installation	Through the window frame
Sound absorbing	40 (-1;-2) dB in open position
i-Flux®	✓
Insect-proof	✓

Technical characteristics		
Airflow	Without acoustic foam	With acoustic foam
Equivalent area	2298 mm ²	1555 mm ²
Q at 1 Pa	1,8 l/s	1,2 l/s
Q at 1 Pa	6,5 m ³ /h	4,4 m ³ /h
Q at 2 Pa	2,7 l/s	1,9 l/s
Q at 10 Pa	6,8 l/s	5,1 l/s
Q at 20 Pa	6,9 l/s	7,6 l/s

Comfort		
Sound reduction D _{n,e,w} (C;Ctr)		
In open position	38 (-1;-2) dB	40 (-1;-2) dB
In closed position	-	

Technical characteristics		
Controllable internal flap	no	
Control options internal flap	n.a.	
U value	-	
Air leakage at 50 Pa	-	
Watertightness in closed position, up to	-	
Watertightness in open position, up to	-	

Dimensions		
Height	35 mm (exterior part) / 45 mm (interior part)	
Length	700 mm	
Slotsize opening	(105,5 × 16) + 7,5 + (105,5 × 16) + 7,5 + (105,5 × 16) + 7,5 + (105,5 × 16) + 7,5 + (105,5 × 16) + 7,5 + (105,5 × 16)	
Length acoustic foam	n.a.	6 × 103 mm
Depth acoustic foam	n.a.	70 mm
Depth plastic sleeve	90 mm	

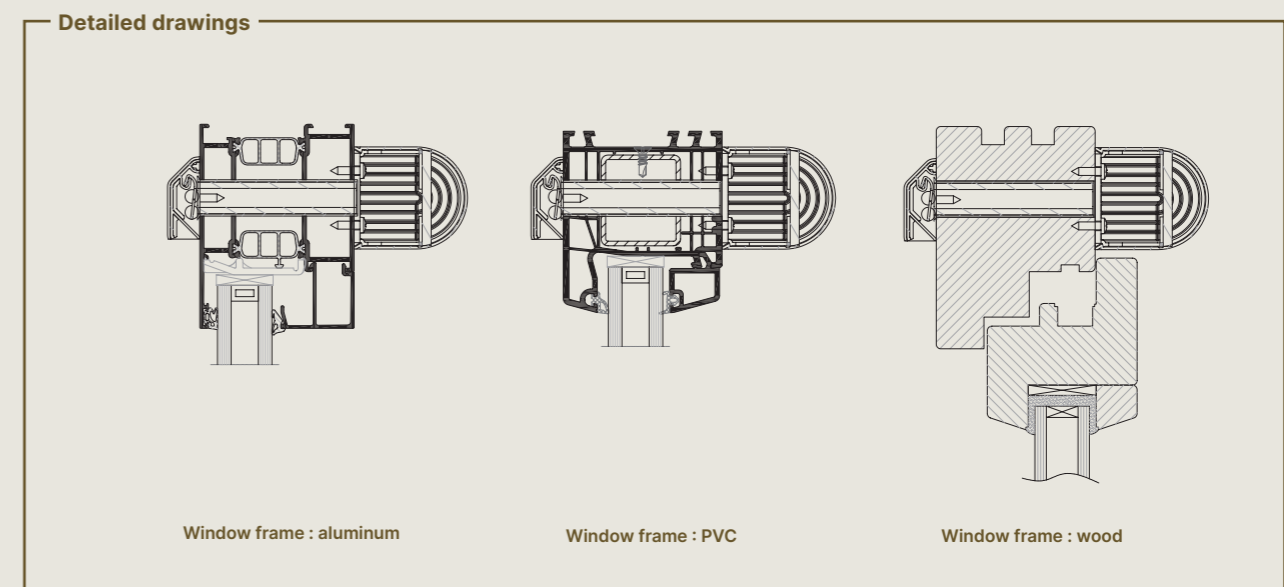

PYRAMID

Smallest vent on the market that provides 5000 mm² EA airflow

The Pyramid is a non-self-regulating compact slotvent kit. It is the smallest vent on the market responding to the ventilation regulation Part F (England & Wales) providing an Equivalent Area of 5000 mm². The Pyramid ventilator is surface mounted on PVC, timber and aluminium windows and is compatible with slot heights from 13 up to 16 mm. The external canopy offers excellent weather protection and incorporates a stainless steel insect mesh screen. The internal slotvent deflects, in open position, the incoming air upwards for optimal spread of fresh air in the room.

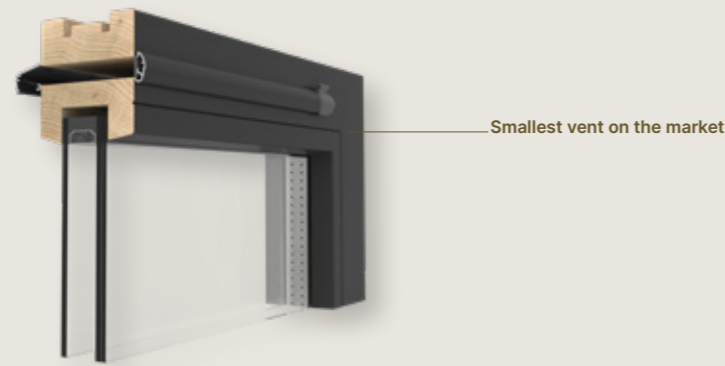

Technical characteristics		
Airflow	2500	5000
Equivalent area	2723 mm ²	5229 mm ²
Q at 1 Pa	2,1 l/s	4,2 l/s
Q at 1 Pa	7,6 m ³ /h	15,1 m ³ /h
Q at 2 Pa	3,1 l/s	6,0 l/s
Q at 10 Pa	7,0 l/s	13,6 l/s
Q at 20 Pa	10,1 l/s	19,4 l/s
Sound reduction Dn,e,w (C;Ctr)		
in open position	36 (0; 0) dB	33 (-1; 0) dB
in closed position	51 (-2; -3) dB	51 (-1; -3) dB
Technical characteristics		
Controllable internal flap	Continuous adjustment	
Control options internal flap	Manual	
U value	-	
Air leakage at 50 Pa	-	
Watertightness in closed position, up to	-	
Watertightness in open position, up to	-	
Dimensions		
Height	25 mm	
Length*	248 mm	410 mm
Slotsize opening	192 × 13	(172 × 13 to 16) + 10 + (172 × 13 to 16)

* other lengths on demand

Technical properties	
Installation	Through the window frame
Coanda effect	✓
Thermal break	-
Self-regulating	-
Insect-proof	-

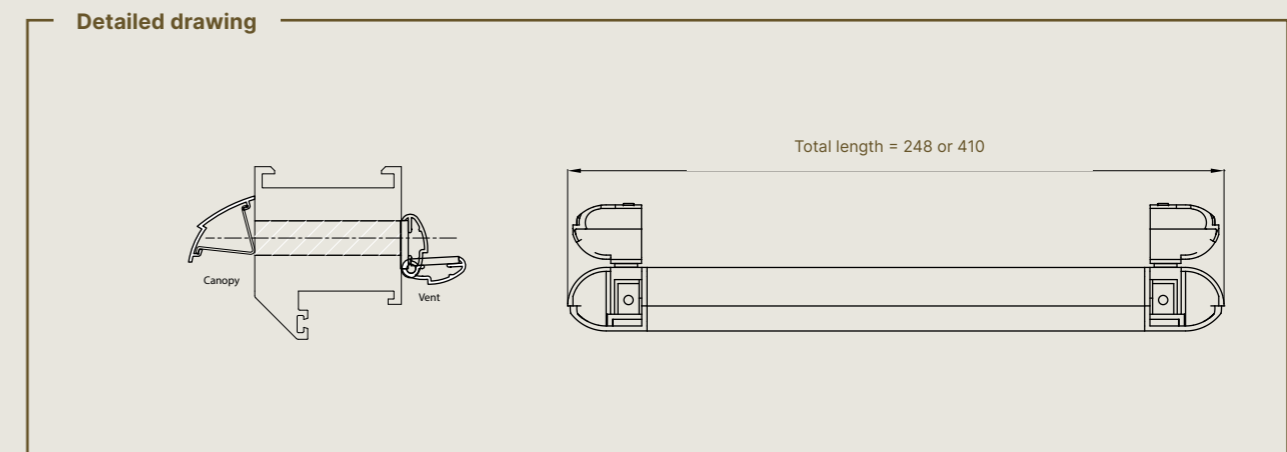

PYRACOUST



Smallest acoustic window vent providing 2500 mm² or 5000 mm² EA

Based on our Pyramid vent, the Pyracoust is the smallest acoustic slotvent (non-self-regulating) responding to the ventilation regulation Part F (England & Wales) providing 2500 mm² or 5000 mm² equivalent area with the best acoustic performances up to 45 dB in open position. The modularity of the acoustic sets provides flexibility for installation and acoustic performance. The external canopy offers excellent weather protection and incorporates a stainless steel insect mesh screen. The slotvent is easy to open and control. The Pyracoust is designed for use with timber, PVC and aluminium window frames.



Slot vent with flexibility of the acoustic module: inside or outside

Technical properties	
Installation	Through the window frame
Sound absorbing	✓
Coanda effect	✓
Thermal break	-
Self-regulating	-
Insect-proof	✓

Technical characteristics				
Airflow	2500 + 1 Acoustic module	2500 + 2 Acoustic modules	5000 + 1 Acoustic module	5000 + 2 Acoustic modules
Equivalent area	2749 mm ²	2736 mm ²	5714 mm ²	5596 mm ²
Q at 1 Pa	2,2 l/s	2,2 l/s	4,5 l/s	4,3 l/s
Q at 1 Pa	7,9 m ³ /h	7,9 m ³ /h	16,2 m ³ /h	15,5 m ³ /h
Q at 2 Pa	3,2 l/s	3,1 l/s	6,4 l/s	6,2 l/s
Q at 10 Pa	7,6 l/s	7,5 l/s	14,4 l/s	14,5 l/s
Q at 20 Pa	11,1 l/s	11 l/s	20,5 l/s	20,8 l/s
Comfort				
Sound reduction D _{n,e,w} (C;Ctr)				
in open position	42 (-1; -2) dB	45 (-2; -3) dB	39 (-1; -2) dB	42 (-2; -4) dB
in closed position	48 (-1; -3) dB	50 (-1; -3) dB	47 (-2; -3) dB	49 (-2; -4) dB
Technical characteristics				
Controllable internal flap	Continuous adjustment			
Control options internal flap	Manual			
U value	-			
Air leakage at 50 Pa	-			
Watertightness in closed position, up to	-			
Watertightness in open position, up to	-			
Dimensions				
Height	40 mm			
Length*	250 mm	412 mm		
Slotsize opening	192 × 13 mm	(172×13) + 10 + (172×13)		

* other lengths on demand

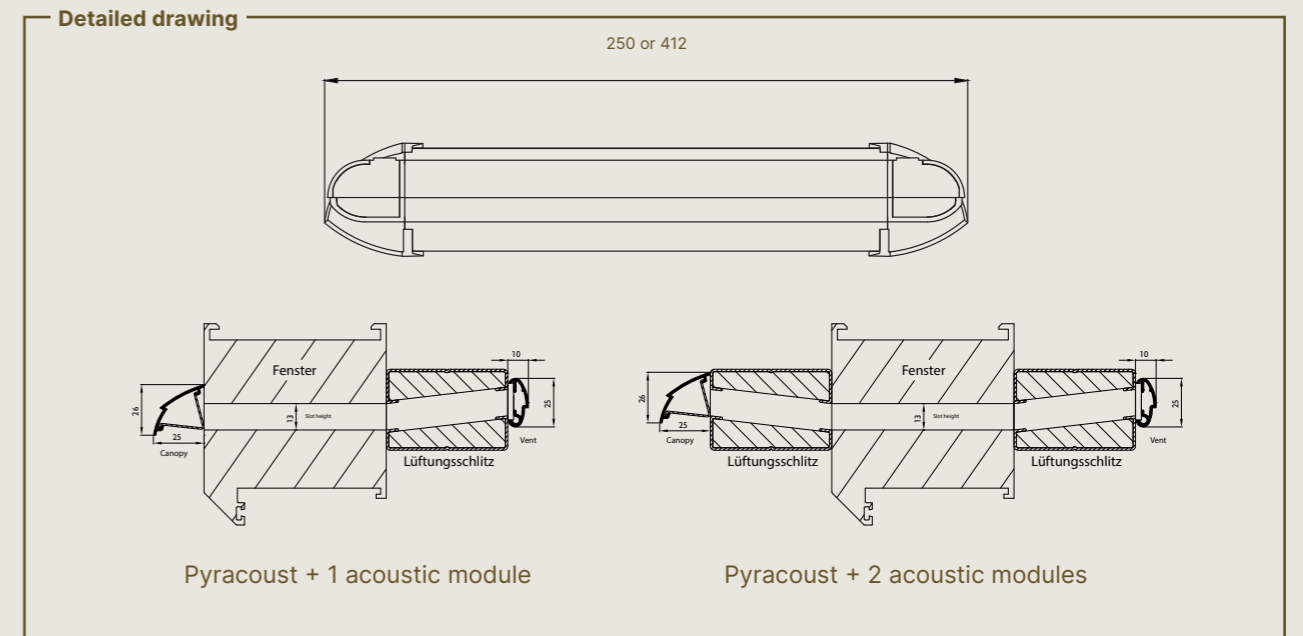

SLOTVENTS

Interior

478 – Flat grille

Type	Length (mm)	Height (mm)	Slotsize opening (mm)	Airflow			
				1 Pa (l/s)	2 Pa (l/s)	2 Pa (m³/h)	Equivalent Area (mm²)
478/1	275	20	230 × 16	1,9	2,8	9,9	2453
478/2	375	20	330 × 16	2,8	3,9	14,2	3512
478/3	475	20	(205 × 16) + 20 + (205 × 16)	3,7	5,4	19,3	4753
478/4	700	20	(315 × 16) + 25 + (315 × 16)	5,6	8,0	28,8	7119

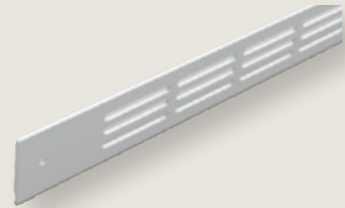

485 – Hit and miss vent

Type	Length (mm)	Height (mm)	Slotsize opening (mm)	Airflow			
				1 Pa (l/s)	2 Pa (l/s)	2 Pa (m³/h)	Equivalent Area (mm²)
485/1	275	22	230 × 16	1,2	1,8	6,4	1551
485/2	375	22	330 × 16	1,9	2,7	9,9	2438
485/3	475	22	(210 × 16) + 20 + (200 × 16)	2,5	3,6	13,1	3214
485/4	700	22	(310 × 16) + 20 + (325 × 16)	4,1	6,0	21,6	5203

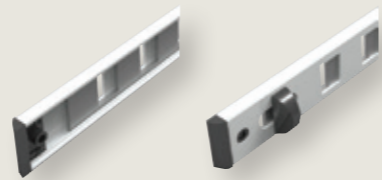

488 – Patio grille

Type	Length (mm)	Height (mm)	Slotsize opening (mm)	Airflow			
				1 Pa (l/s)	2 Pa (l/s)	2 Pa (m³/h)	Equivalent Area (mm²)
488/1	275	30	250 × 25	3,1	4,3	15,5	3899
488/2	375	30	(165 × 25) + 20 + (165 × 25)	4,3	5,9	21,4	5423
488/3	475	30	(215 × 25) + 20 + (215 × 25)	4,5	6,8	24,6	5787
488/4	700	30	(325 × 25) + 25 + (325 × 25)	8,5	12,1	43,5	10839

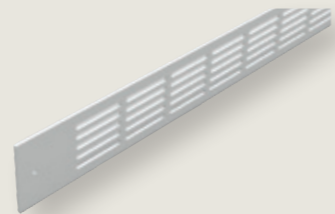

489 – Bar grille

Type	Length (mm)	Height (mm)	Slotsize opening (mm)	Airflow			
				1 Pa (l/s)	2 Pa (l/s)	2 Pa (m³/h)	Equivalent Area (mm²)
489/1	275	24	237 × 18	1,7	2,5	8,9	2202
489/2	375	24	337 × 18	2,2	3,2	11,7	2822
489/3	475	24	(210 × 18) + 17 + (210 × 18)	3,0	4,3	15,3	3807
489/4	700	24	(320 × 18) + 22 + (320 × 18)	5,1	7,2	25,8	6477

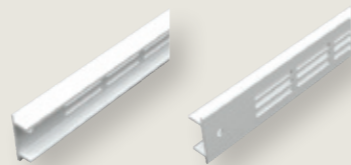

787AK – Tipvent

Type	Length (mm)	Height (mm)	Slotsize opening (mm)	Airflow			
				1 Pa (l/s)	2 Pa (l/s)	2 Pa (m³/h)	Equivalent Area (mm²)
787AK/1	275	28	245 × 16	3,2	4,6	16,7	4127
787AK/2	375	28	345 × 16	4,0	5,7	20,5	5108
787AK/3	475	28	(215 × 16) + 20 + (215 × 16)	5,1	7,3	26,3	6525
787AK/4	700	28	(325 × 16) + 25 + (325 × 16)	9,0	12,9	46,5	11455

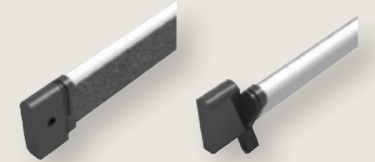

Exterior

471 – Self regulating canopy

Type	Length (mm)	Height (mm)	Slotsize opening (mm)	Airflow			
				1 Pa (l/s)	2 Pa (l/s)	2 Pa (m³/h)	Equivalent Area (mm²)
471/1	275	35	250 × 25	1,4	2,0	7,3	1785
471/2	375	35	350 × 25	2,0	3,0	10,8	2527
471/3	475	35	(215 × 25) + 20 + (215 × 25)	2,3	3,7	13,2	2951
471/4	700	35	(325 × 25) + 20 + (325 × 25)	4,0	6,0	21,5	5055

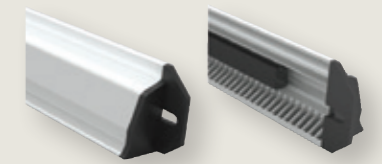

Section detail interior slotvents

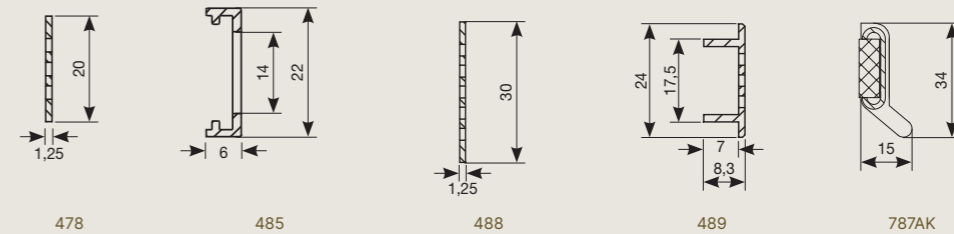

Section detail exterior slotvents

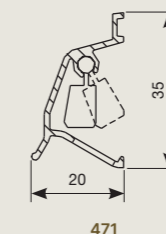



COMBINED VENTILATION AND SUN PROTECTION OVERFRAME

With its Fixvent range, Renson offers an aesthetic and comfortable solution that combines windproof sun protection and ventilation.



VENTILATION AND
SUN PROTECTION

FIXVENT® MONO AK



The perfect combination of ventilation and windproof sun protection

This product, which is installed on the window as a monobloc, can effortlessly be used in newbuild, (major) renovation and other projects. What's more, due to their identical look and feel, Fixvent Mono AK always combines exceptionally with Fixscreen Mono AK to combine windproof sun protection and insect protection in a single product.

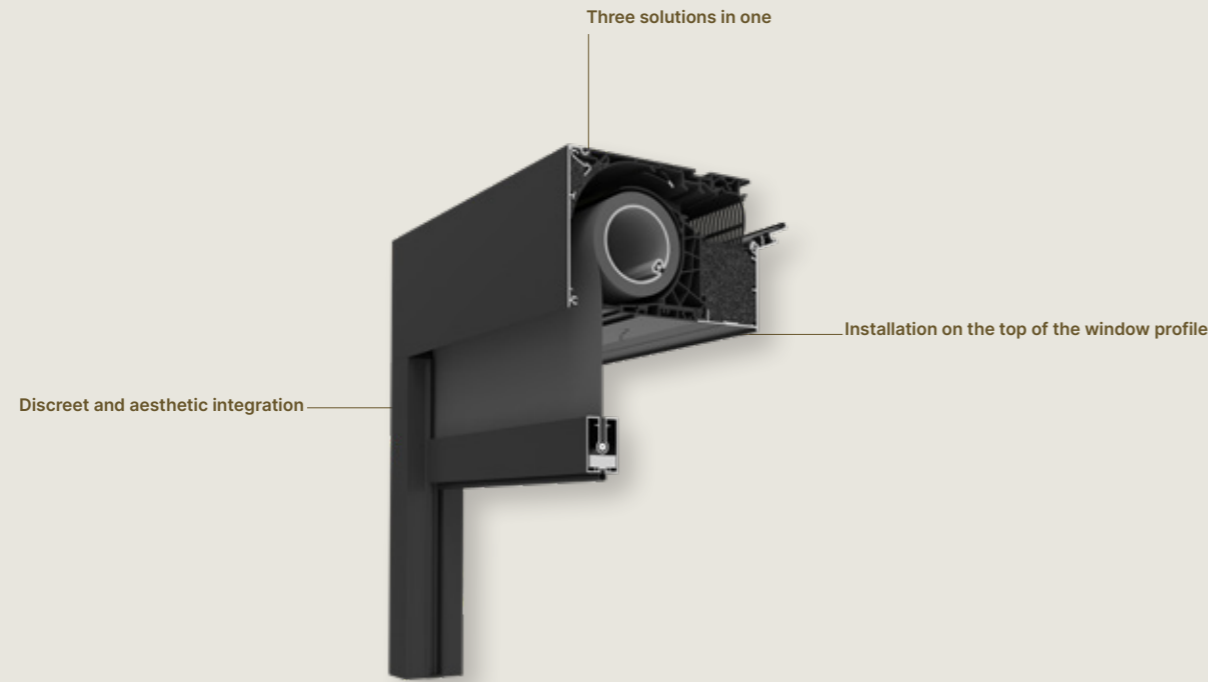

Technical properties	Fixvent Mono AK	Fixvent Mono AK Ultra	Fixvent Mono AK Extreme
Installation	On top of the window, profiles ranging from 50 to 215 mm		
With thermal break		✓	
Self-regulating at 2 Pa		✓	
Sound-damping	up to 40 (-1;-4) dB	up to 45 (-1;-5) dB	up to 48 (-2;-5) dB
I-Flux		✓	
Insect-proof		✓	

Ventilation						
Airflow		Small	Medium	Large	X-Large	XX-Large
Equivalent Area	Fixvent® Mono AK	18324 mm ² /m				
	Fixvent® Mono AK ULTRA	4836 mm ² /m				
	Fixvent® Mono AK EXTREME	2800 mm ² /m				
Q at 1 Pa	Fixvent® Mono AK	12,8 l/s/m				
	Fixvent® Mono AK ULTRA	3,7 l/s/m				
	Fixvent® Mono AK EXTREME	2,1 l/s/m				
Acoustic damping D _{new} (C;C _{tr}) in open position (fabric rolled up)						
Fixvent® Mono AK		33(0;-2)dB	35(0;-3)dB	36(-1;-4)dB	37(-1;-4)dB	40(-1;-4)dB
Fixvent® Mono AK Ultra		n/a	38(0;-2)dB	40(-1;-4)dB	43(-1;-4)dB	45(-1;-5)dB
Fixvent® Mono AK Extreme		n/a	43(0;-3)dB	43(0;-3)dB	46(-1;-4)dB	48(-2;-5)dB
Technical details						
U value (W/m ² K)						
Fixvent® Mono AK		1.47	0.98	0.80	0.77	0.72
Fixvent® Mono AK Ultra		n/a	0.70	0.55	0.46	0.41
Fixvent® Mono AK Extreme		n/a	0.62	0.47	0.38	0.32
Airflow leakage in closed position		< 15% at 50 Pa				
Design						
Head box size (HxD) (mm)		132 × 167	132 × 197	132 × 227	132 × 257	132 × 287
Compatible window thicknesses		50-94 mm	95-124 mm	125-154 mm	155-184 mm	185-215 mm
Connect&Go and Click&Safe		Easy assembly and removal of the fabric set				
Dimensions						
Single (one fabric - one control)		4000 × 3000 mm (12 m ²)				
Joined (two parts - two motors)		6000 × 3000 mm (18 m ²)				
Bottom bar		30 × 57 mm				
Windproofness						
Wind classification EN13561:2004		3				
Wind tunnel report		N°113-25809				
Guaranteed wind resistance		Up to 130 km/h in closed position				
Controls						
Screen		Motor				
Ventilation valve		Manual, motor, rod				

Please note
- Small head box not available for Fixvent Mono ULTRA/EXTREME.

Recessed masonry drawing

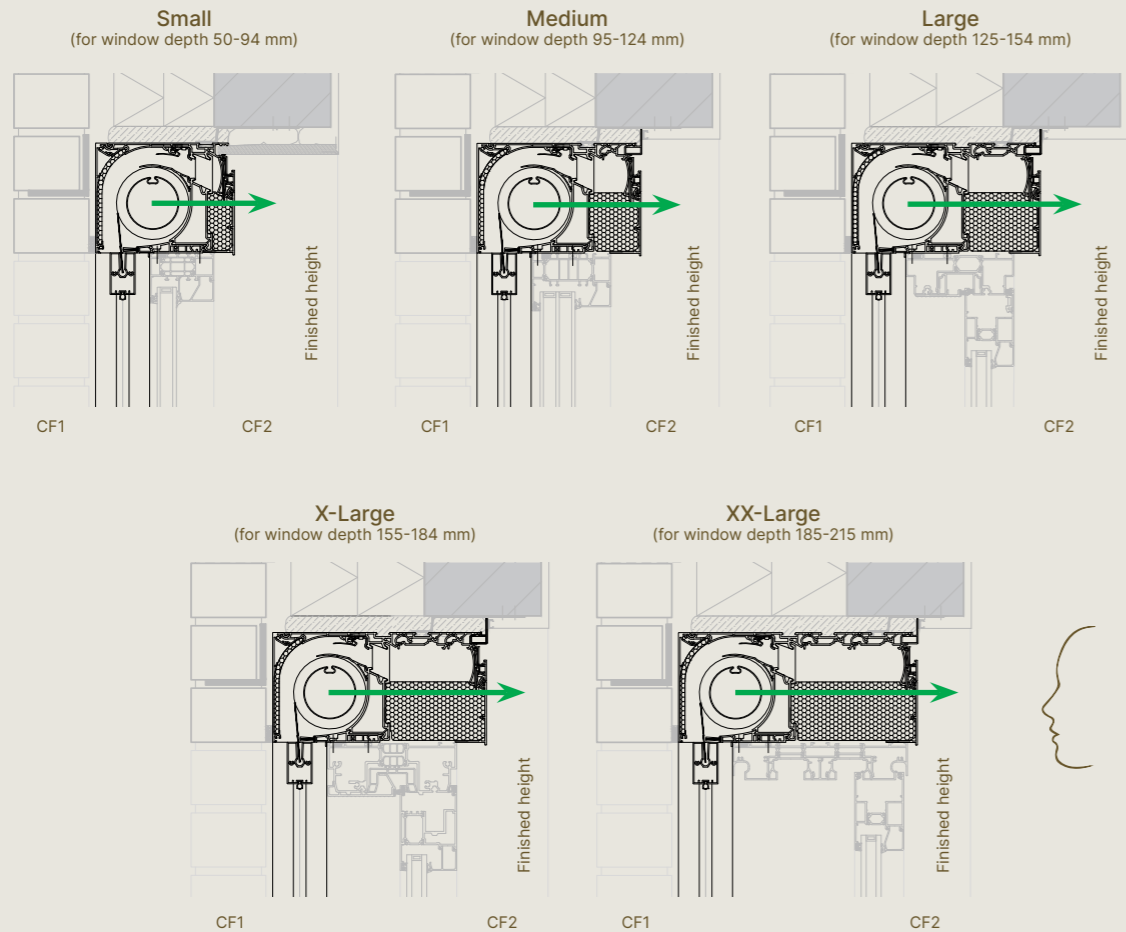

Improved acoustic comfort or U value

Optional: deeper head box size compared to standard window group for better acoustic comfort or U value

Example 1: Medium on narrower window Example 2: Large on narrower window

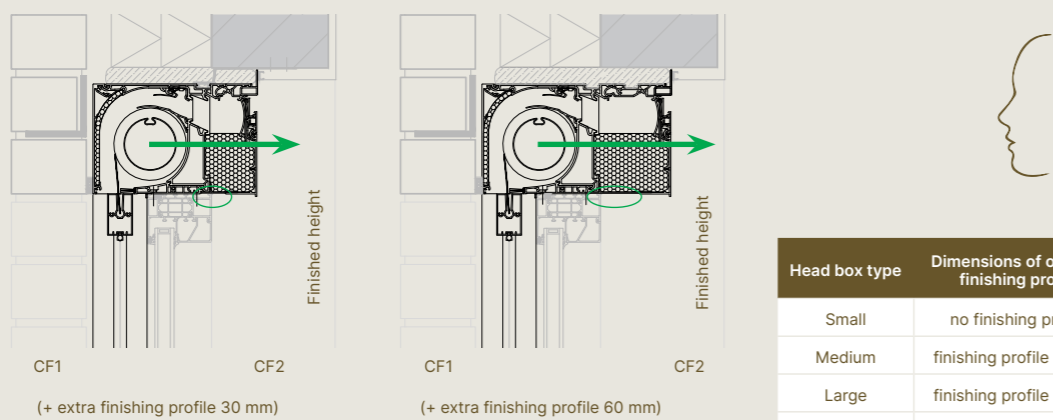

Head box type	Dimensions of optional finishing profile
Small	no finishing profile
Medium	finishing profile 30 mm
Large	finishing profile 60 mm
X-Large	finishing profile 90 mm
XX-Large	finishing profile 120 mm

Note: Fixvent Mono AK Ultra/Extreme is always supplied with a finishing profile as standard.

Viewing direction determines choice of left or right cable feed ← Direction in which fabric set should be removed



FIXVENT® MONO UT



The perfect combination of ventilation, windproof sun protection and insect protection for non-residential construction

Just like Fixvent Mono AK, Fixvent Mono UT combines windproof sun protection, insect protection and ventilation in a single product. That said, this UT version has been specifically developed for non-residential construction, making it the perfect solution for applications including schools and office buildings that require high air Airflows.

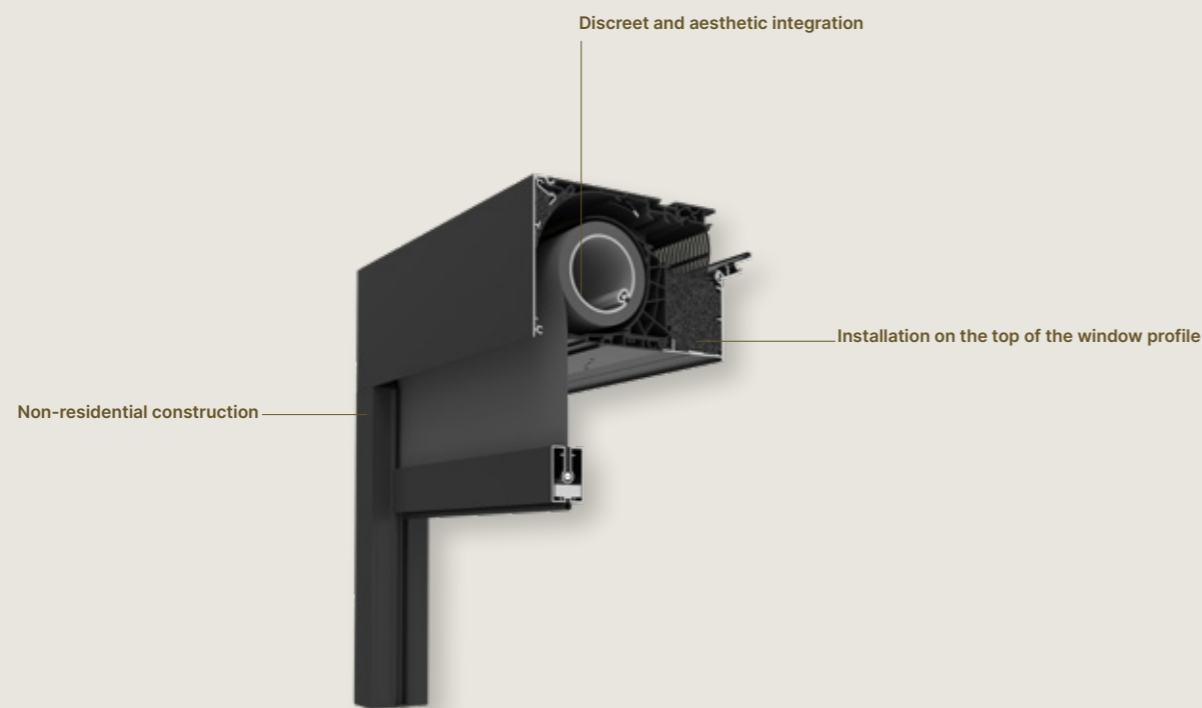

Ventilation						
Airflow		Small	Medium	Large	X-Large	XX-Large
Equivalent Area	Fixvent® Mono UT	19724 mm ² /m				
	Fixvent® Mono UT ULTRA	4836 mm ² /m				
Q at 1 Pa	Fixvent® Mono UT	15.5 l/s/m				
	Fixvent® Mono UT ULTRA	3.7 l/s/m				
Acoustic damping D _{new} (C;C _{tr}) in open position (fabric rolled up)						
Fixvent® Mono UT		33(0;-2)dB	35(0;-3)dB	36(-1;-4)dB	37(-1;-4)dB	40(-1;-4)dB
Fixvent® Mono UT Ultra		n/a	38(0;-2)dB	40(-1;-4)dB	43(-1;-4)dB	45(-1;-5)dB
Technical details						
U value (W/m ² K)						
Fixvent® Mono UT		1.47	0.98	0.80	0.77	0.72
Fixvent® Mono UT Ultra		n/a	0.70	0.55	0.46	0.41
Leakage flow in closed position		< 15% at 50 Pa				
Design		Small	Medium	Large	X-Large	XX-Large
Head box size (HxD) (mm)		132 × 167	132 × 197	132 × 227	132 × 257	132 × 287
Compatible window thicknesses		50-94 mm	95-124 mm	125-154 mm	155-184 mm	185-215 mm
Connect&Go and Click&Safe		Easy assembly and removal of the fabric set				
Dimensions						
Single (one fabric - one control)		4000 × 3000 mm (12 m ²)				
Joined (two parts - two motors)		6000 × 3000 mm (18 m ²)				
Bottom bar (D x H)		30 × 57 mm				
Windproofness						
Wind classification EN13561:2004		3				
Wind tunnel report		N°113-25809				
Guaranteed wind resistance		Up to 130 km/h in closed position				
Controls						
Screen		Motor				
Ventilation valve		Manual, motor, rod				

Please note
- Small head box not available for Fixvent Mono UT ULTRA.

Technical properties	Fixvent Mono UT	Fixvent Mono UT Ultra
Installation	On top of the window, profiles ranging from 50 to 215 mm	
With thermal break	✓	
Self-regulating at 2 Pa	✓	
Sound-damping	up to 40 (-1;-4) dB	up to 45 (-1;-5) dB
I-Flux	✓	
Insect-proof	✓	

Recessed masonry drawing

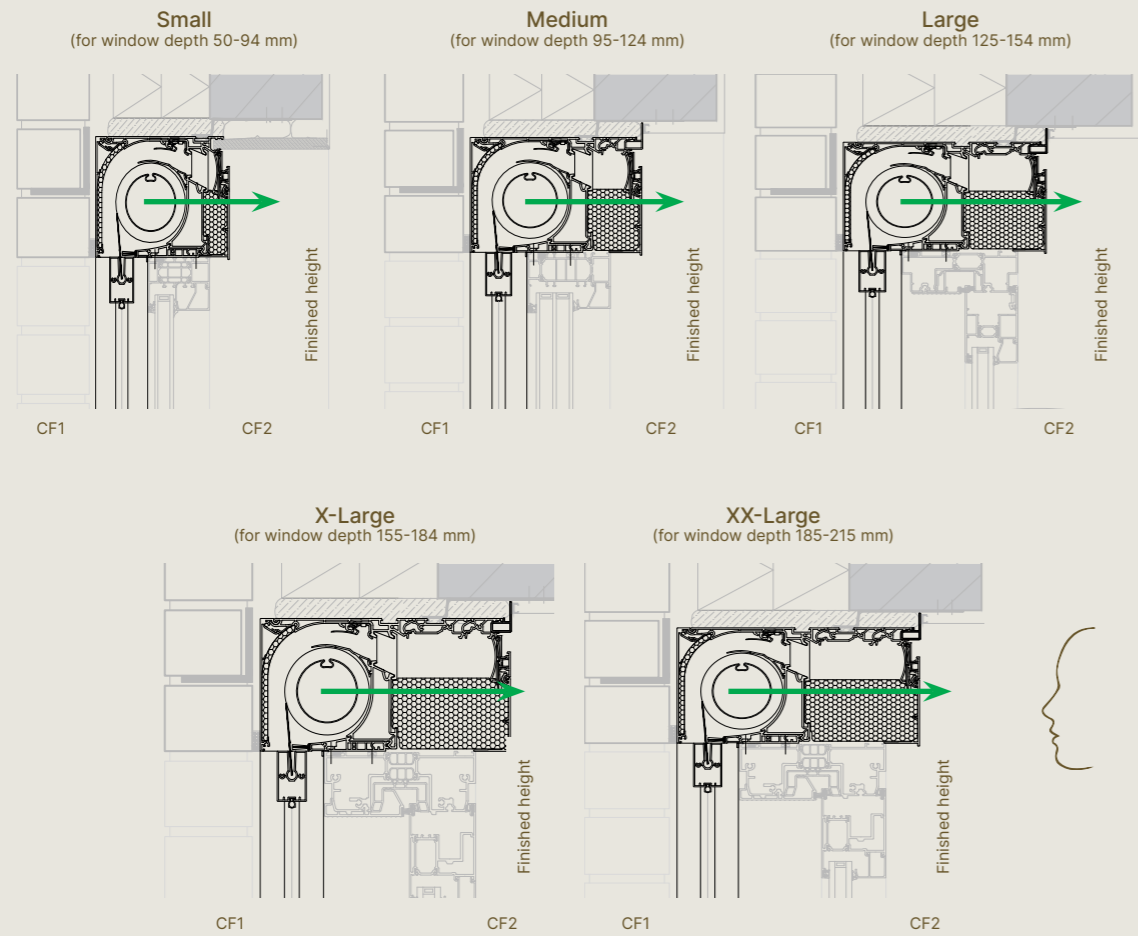

Improved acoustic comfort or U value

Optional: deeper head box size compared to standard window group for better acoustic comfort or U value

Example 1: Medium on narrower window

Example 2: Large on narrower window

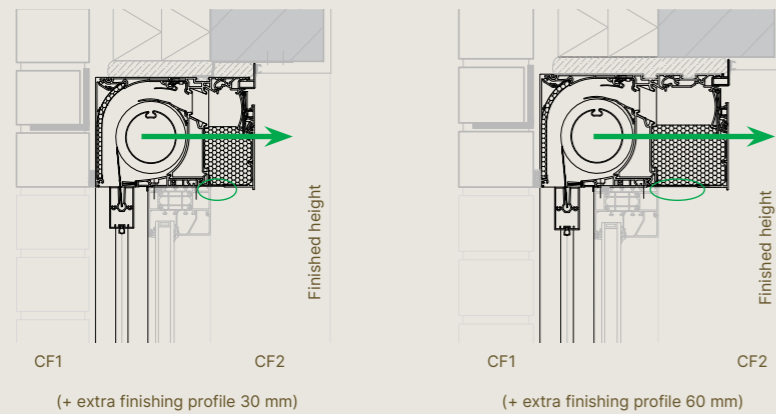

Head box type	Dimensions of optional finishing profile
Small	no finishing profile
Medium	finishing profile 30 mm
Large	finishing profile 60 mm
X-Large	finishing profile 90 mm
XX-Large	finishing profile 120 mm

Note: Fixvent Mono UT Ultra is always supplied with a finishing profile as standard.

Viewing direction determines choice of left or right cable feed → Direction in which fabric set should be removed



VENTILATOIN AND SUN PROTECTION

GENERAL

GLAZING GASKETS

For the placement of glazed-in vents on the glass, Renson recommends specially designed glazing gaskets:

- No. 019, colour: black, for glass thickness 36-44 mm
- No. 029, colour: black, for glass thickness 28-36 mm
- No. 034, colour: grey, for glass thickness 20-28 mm
- No. 039, colour: black, for glass thickness 20-28 mm

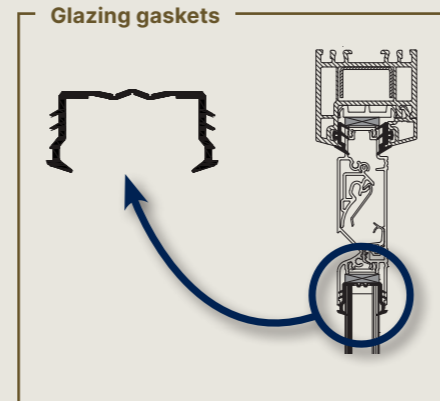

POSSIBLE CONTROLS

- Manual control: the inner valve can be opened/closed manually (e.g. Invisivent). Levers are available in lengths of 30, 40, 50, 60 or 70 mm.

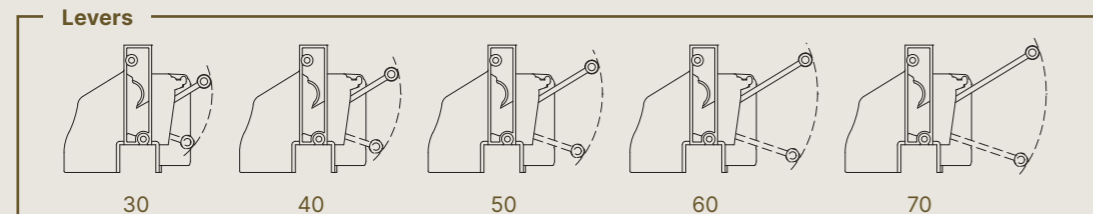

- Cord control: the standard length for cord control is 1000 mm, other dimensions are available upon request.
- Rod control: the standard length for rod control is 1000 mm, other dimensions are available upon request. The rod can be powder coated in any RAL colour. A hook-up rod, a transmission rod and a sliding knob are all possible.
- Motor control: possible using an 'ON/OFF' or '0 - 10 V' switch (for home automation) switch. Standard cable length: 3 m (except for THL100(V)).
- Not all control options are possible for all products.

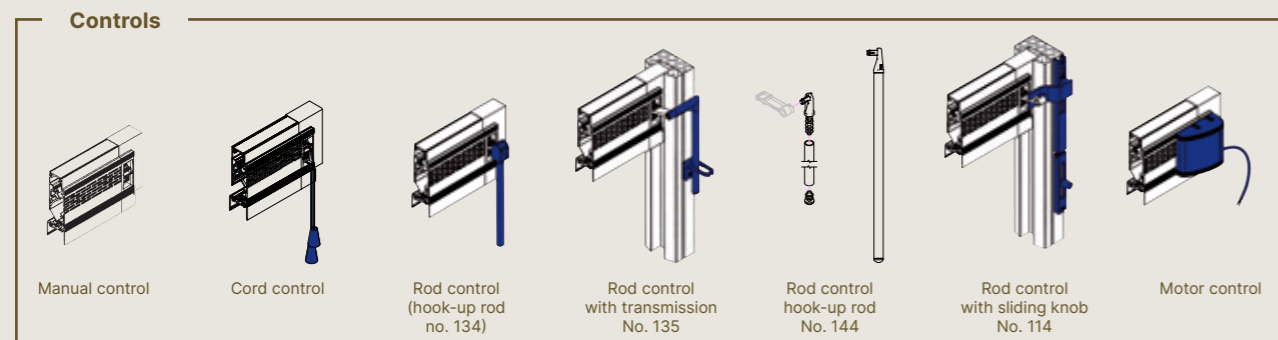

FINISHING

- Interior and exterior profile material: extruded AlMgSi 0.5 aluminium
- Interior and exterior profile finishing: bronze or natural colour anodised (E6/EV1, except Oxyvent, Endura Twist and the Sonovent range) or powder coated in any possible RAL colour. Dual colour possible.
- As standard, the profile lengths are pre-treated in accordance with Seaside Quality A
- Pre-treatment (pre-anodisation) is recommended for installation in a very aggressive environment such as the coastal region, industrial area
- Thermal break: extruded PVC
- End cap material: ASA polymer type Luran S (true colour, weather and UV resistant)
- End cap colour:
 - The end caps for window vents on the window profile or on the glass are available in several standard colours, as 'standard coloured-core end cap colours'. Depending on the product, the coloured-core end cap colours may differ.
 - The end caps on Sliding vents are only available in black.
 - End caps can always be wet coated in a colour of your choice, subject to a surcharge.

MAINTENANCE

Nearly all Renson® window vents on the window profile are fitted with a removable inner profile, which makes it possible to clean the vent quickly and easily using a damp cloth or vacuum cleaner. We recommend cleaning window vents at least once a year. The aluminium interior and exterior profiles can be cleaned using a damp cloth and non-abrasive cleaning product. Rinse well with clean water.



TRANSOM PROFILES

A transom profile (height 40 mm) is available for window vents installed at transom. Our transom profiles are developed to be cut to length quickly and easily and can also be customised. These profiles are available in their natural colour or can be coated in any Renson colour.

For THM90^{EVO}, Renson® has developed special models that do not require any transom profiles: THM90PB^{EVO} for installation below the window and THM90TR^{EVO} for installation in the glass between profiles (at transom).

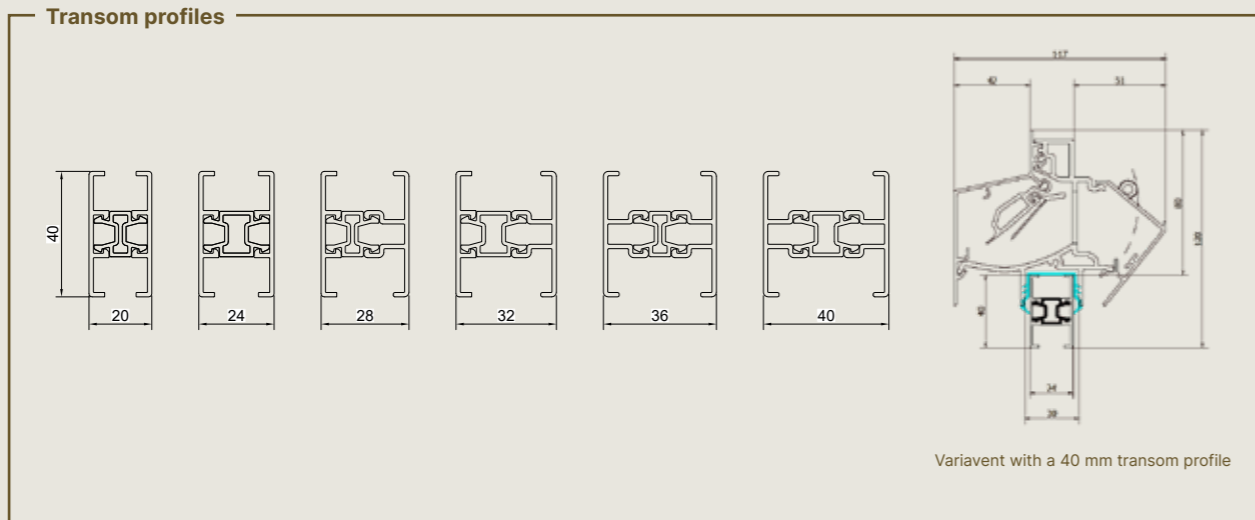

POLLUX®: OPTIONAL FINE DUST AND POLLEN FILTER

If your customer is living in an environment with excessive fine dust (such as near a motorway or industrial area), or if they suffer from hay fever (caused by pollen), an optional Pollux filter in their Renson® window vent can filter out any fine dust and pollen while maintaining a constant supply of fresh air.

A Pollux filter can be added to the following Renson window vents:

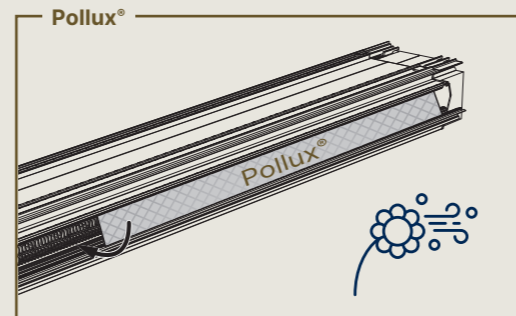

	Pollux type 01	Pollux type 02	Pollux type 03	Pollux type 04
AR60	✓	-	-	-
Variavent	-	✓	-	-
Sonovent	-	-	✓	-
Sonovent compact	-	✓	-	-
Invisivent AIR / COMFORT	-	-	-	✓

TESTING AND STANDARDS

Renson products are manufactured, compliant and/or tested to the following standards: EN ISO 140-10, EN ISO 717-1, EN 1026, EN 1027, EN 13141-1, EN 12020-2, EN AW 6063 T66, NBN D50-001, EN 10077-2, DIN 16491, prEN 1627, prEN 1628, prEN 1629 and prEN 1630. Waterproofness and windtightness is tested to EN1027 and EN1026 standards.

INTELLECTUAL PROPERTY

Our innovative range of window vents is protected by multiple intellectual property rights.



AMBASSADORSHIP

You are convinced about our products and enthusiastically share this with the world. In turn, we are proud that you are the connecting factor between Renson and your customers. Just for you, we created the Renson Ambassadorship: a long-term partnership. This quality label guarantees your customers that you are a reliable expert in ventilation with excellent product knowledge and perfect service, from installation to the first service visit.

What does your Ambassadorship stand for?

- You share your passion for Renson with a strong professional network.
- Every two years, you will be invited to our Ambassador Days where you can network with your colleagues to your heart's content.
- You are among the first to gain access to innovative and market-specific products and solutions.
- You have access to exclusive promotions for end customers, supported by media campaigns (online/offline).
- Through our lead tool, you will get one-to-one leads per region, which we receive via our communications, trade shows and events.
- We put you in the spotlight regularly and support you through co-branding to develop the Renson brand in your region.
- We promote you to your end customers.
- You may wear the exclusive quality label of Renson Ambassador.

**WANT TO JOIN
OUR RENSON AMBASSADOR FAMILY?
GET IN TOUCH WITH YOUR
RENSON CONTACT.**



**SOUDAL QUICK-STEP PRO CYCLING TEAM
POWERED BY RENSON**





* L 0 0 0 0 5 2 7 *

All photos shown are solely for illustration purposes and are a snapshot of the usage situation. The actual product may vary due to adjustments to the product. Renson® reserves the right to make technical changes to the products shown. The most recent brochures are available for download at www.renson.net